

Zero Point Clamping System **SPEEDY classic 2**

Set your manu-
facturing to





GO!

Maximum productivity

- Using the zero point clamping system SPEEDY classic you will increase your production times to a maximum. Adjustment and checking processes are no longer necessary at all, this means more time for your production.
- With the zero point clamping system by STARK, adjustment and checking processes on processing machines can be carried out more easily.

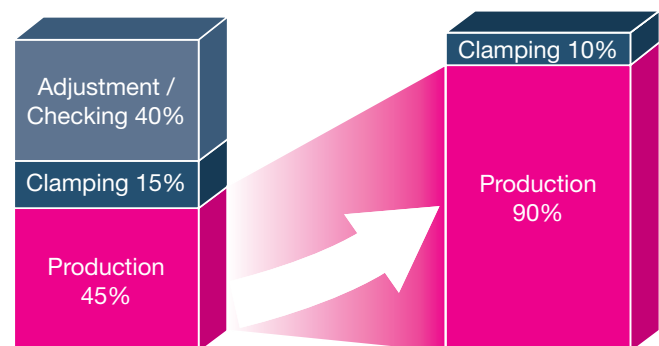

Maximum flexibility

- SPEEDY classic has a common interface. As a result all equipment can be used on all machines.

Maximum machine availability

- Machining processes can be interrupted for urgent orders without loss of time and completed later.

SPEEDY classic – an investment that pays for itself in a very short space of time.



STARK clamping systems overview

Differentiation is by the method of actuation and varying size of the retractable nipples:

SPEEDY classic - clamp mechanically / release hydraulically

Most comprehensive and versatile zero point clamping system,

- Four sizes and numerous variants

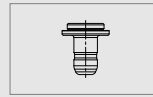

SPEEDY
classic **1**

Catalogue order no. WM-020-217-02-en



SPEEDY
classic **2**

Catalogue order no. WM-020-276-03-en

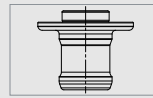

SPEEDY
classic **3**

Catalogue order no. WM-020-278-02-en



SPEEDY
classic **4**

Catalogue order no. WM-020-280-01-en

SPEEDY metec - clamp / release mechanically

Robust mechanical zero point clamping system for simple, low-cost solutions,

- Three sizes



SPEEDY
metec **1**

Catalogue order no. WM-020-293-02-en



SPEEDY
metec **2**

Catalogue order no. WM-020-293-02-en

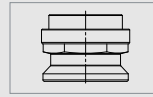

SPEEDY
metec **3**

Catalogue order no. WM-020-293-02-en

SPEEDY airtec - clamp mech. / release pneum.

Pneumatic zero point clamping system,

- One size and numerous variants

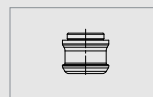

SPEEDY
airtec **1**

Catalogue order no. WM-020-288-02-en

SPEEDY hydratec - clamp / release hydraulically

Hydraulic, double action zero point clamping system for very high clamping speeds,

- One size and numerous variants



SPEEDY
hydratec **1**

Catalogue order no. WM-020-290-02-en

system 3000 - clamp / release hydraulically

Double action zero point clamping system with small size and high clamping force,

- One size and numerous variants

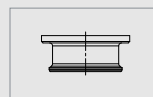

system **3000**

Catalogue order no. WM-020-333-02-en

system 4000 - custom systems

Flexible zero point clamping system for mechanical, pneumatic and hydraulic applications,

- One size and numerous variants

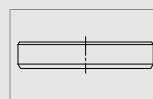

system **4000**

Catalogue order no. WM-020-067-00-en

Table of Contents SPEEDY classic 2

i	Information	Systems overview / Table of Contents. i.4 - i.5 Function description / Advantages / Technical data / Tilting torque calculation. i.6 - i.11
1	Flush Mount	STANDARD Flush Mount round 1.2 STANDARD Flush Mount square. 1.3 STANDARD Flush Mounting round with media ducts 1.4 TORNADO Flush Mounting round / square with raised supports and blow-out ducts . . . 1.5 TORNADO Flush Mounting round / square with raised supports, blow-out ducts and coolant drainage 1.6 TWISTER Flush Mounting round with raised supports and blow-out ducts 1.7 STANDARD Module round 1.8 TORNADO Module round with raised supports and blow-out ducts 1.9
		
2	Surface Mount	STANDARD Surface Mount round / square. 2.2 STANDARD Surface Mount round / square with centring shank 2.3 SET 4 / SET 6. 2.4 Fixing clamp 1 / 2 / 3 incl. fastening 2.5 - 2.7 Accessories for pipework 2.8 - 2.11
		
3	Retractable nipple	Retractable nipple with zero point / with equaliser / without equaliser 3.2 - 3.3 Nipple fastening D / E 3.4 - 3.5 Countersunk head screw / Bearing plate. 3.6 Spacer washer for TWISTER. 3.7
		
4	Pressure boosters	RECORD / BOOSTER. 4.2 Hydraulic hose 4.3 Pedal control / DHF pedal control 4.3 - 4.4 Hydraulic pump set. 4.4 - 4.5
		
5	Plates, angles, mounting towers	Fast closing clamp plates / Fast closing clamp face plate 5.2 Angle / Double angle. 5.3 Mounting tower with / without valve system 5.4 Vice pallet 5.5
		
6	Media ducts	Media duct NW 4 coupling mechanism / coupling nipple 6.3 - 6.4 Multiple coupling NW4 coupling mechanism / coupling nipple. 6.5 - 6.6 Media duct NW 4 blanking plug 6.7 Media duct pliers 6.8 Clamp control valve mechanical 6.9
		
7	SPEEDY accessories	Shut-off valve 7.1 Torque wrench / Sealing plug 7.2 Transport protection / Service-set O-rings & cup springs / Circlip pliers 7.3 - 7.4 Mechanical insertion force tester. 7.5 Hydraulic installation aid / Installation aid. 7.6
		

Function description SPEEDY classic 2 - positioning and clamping in one function

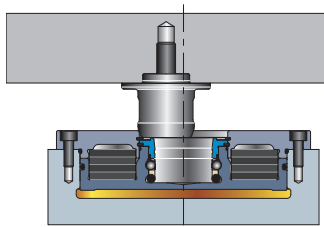

Insert and pre-position

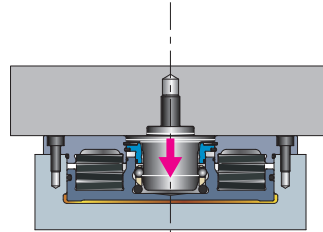

Position and clamp

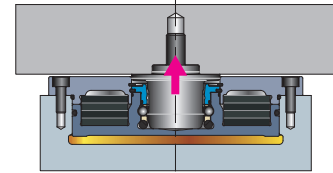

Release and lift off

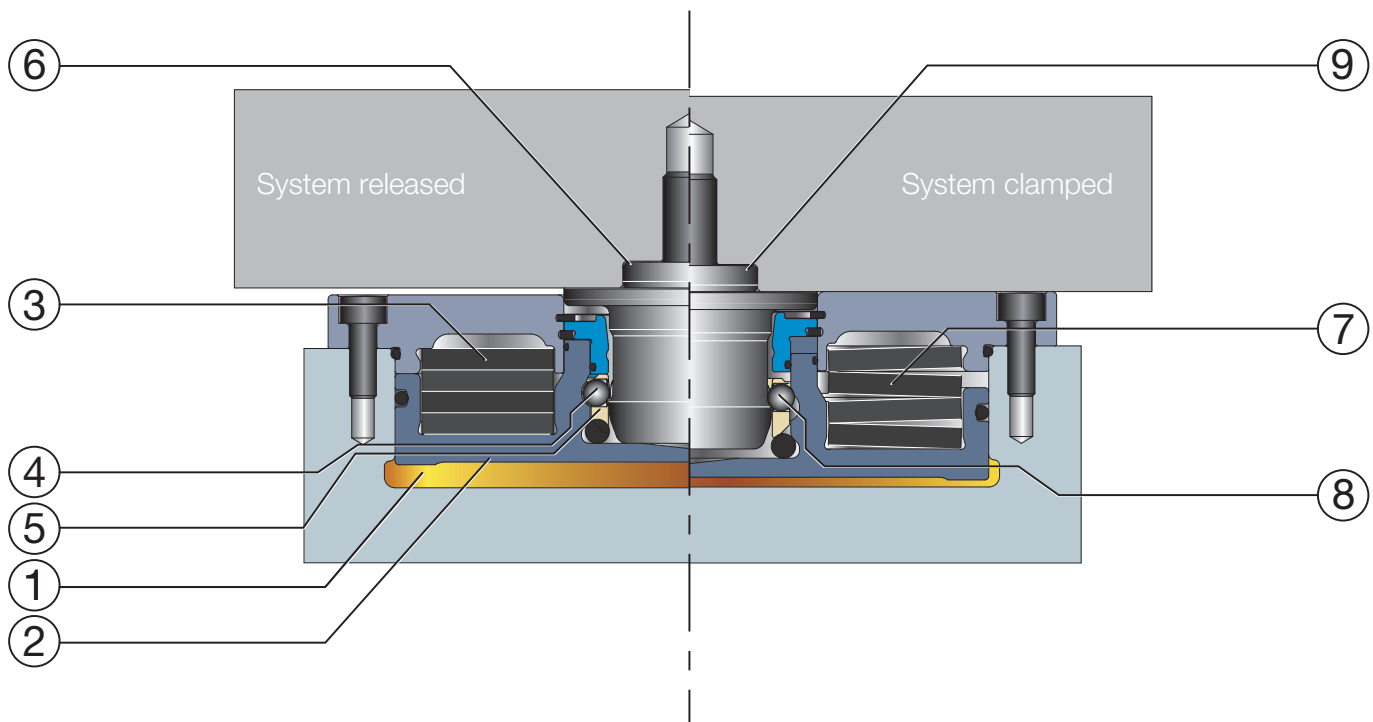

Releasing hydraulically

- Hydraulic pressure (1) is applied to the piston (2) and the piston moves upwards.
The spring pack (3) is compressed.
- The balls (4) in the ball cage (5) move outwards to the parking position.
- The retractable nipple (6) moves into the fast closing clamp until it is in contact with the base of the piston.
- The retractable nipple (6) is pre-positioned.

Clamping mechanically

- The hydraulics are de-pressurised, the oil pressure drops to 0 bar.
- The spring pre-load is applied via the piston (2), the piston moves downwards.
The fit is aligned, the retractable nipple (9) highly precisely positioned.
- The balls (8) are positively positioned between piston and retractable nipple in the related contour.
- The pre-load on the springs (7) now acts downwards directly and constantly on the retractable nipple.

Proven technology with a system - original down to the smallest detail

Advantages
to be worth it!

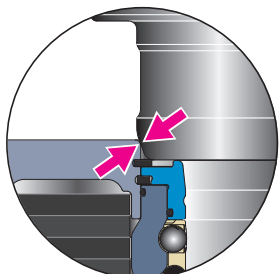

Wear-proof insertion and pre-centring

Due to the special retractable nipple contour, the fit is not damaged on insertion in the SPEEDY.

High alloy tool steel provides resilience to wear.

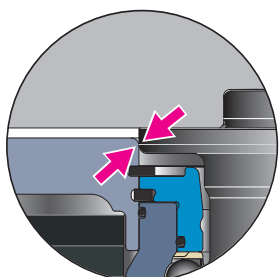

Matched radii on the bore

Matched radii on the SPEEDY and on the insertion nipple result in exact pre-positioning.

The fit is automatically aligned by drawing in the pallet.
The operator only needs to set down or remove the pallet.

No chips can be jammed in the cylindrical bore.

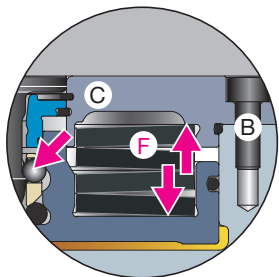

High positioning accuracy due to optimal application of force - no bending or lifting

The retractable nipples are fixed positively and with very high precision - this action has a vibration attenuation effect and increases the quality of the surface to be machined as well as the life of the tools.

The force from the springs (F) acts close to the fastening screw (B). As a result there is no bending on the cover (C).

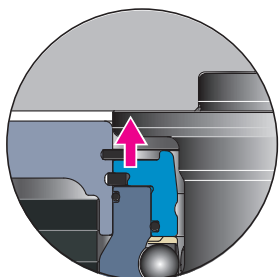

Lifting out of the fit

On release the retractable nipple is lifted out of the fit in a controlled manner and the operator can see that the system has been released. The result is safe and very straightforward handling.

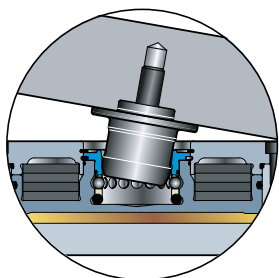

Lifting out/off at an angle

Workpieces, jigs or pallets changed without jamming. Particularly suitable in case of asymmetrical weight distribution above the pallet.

Other advantages of SPEEDY classic 2 - discover the difference

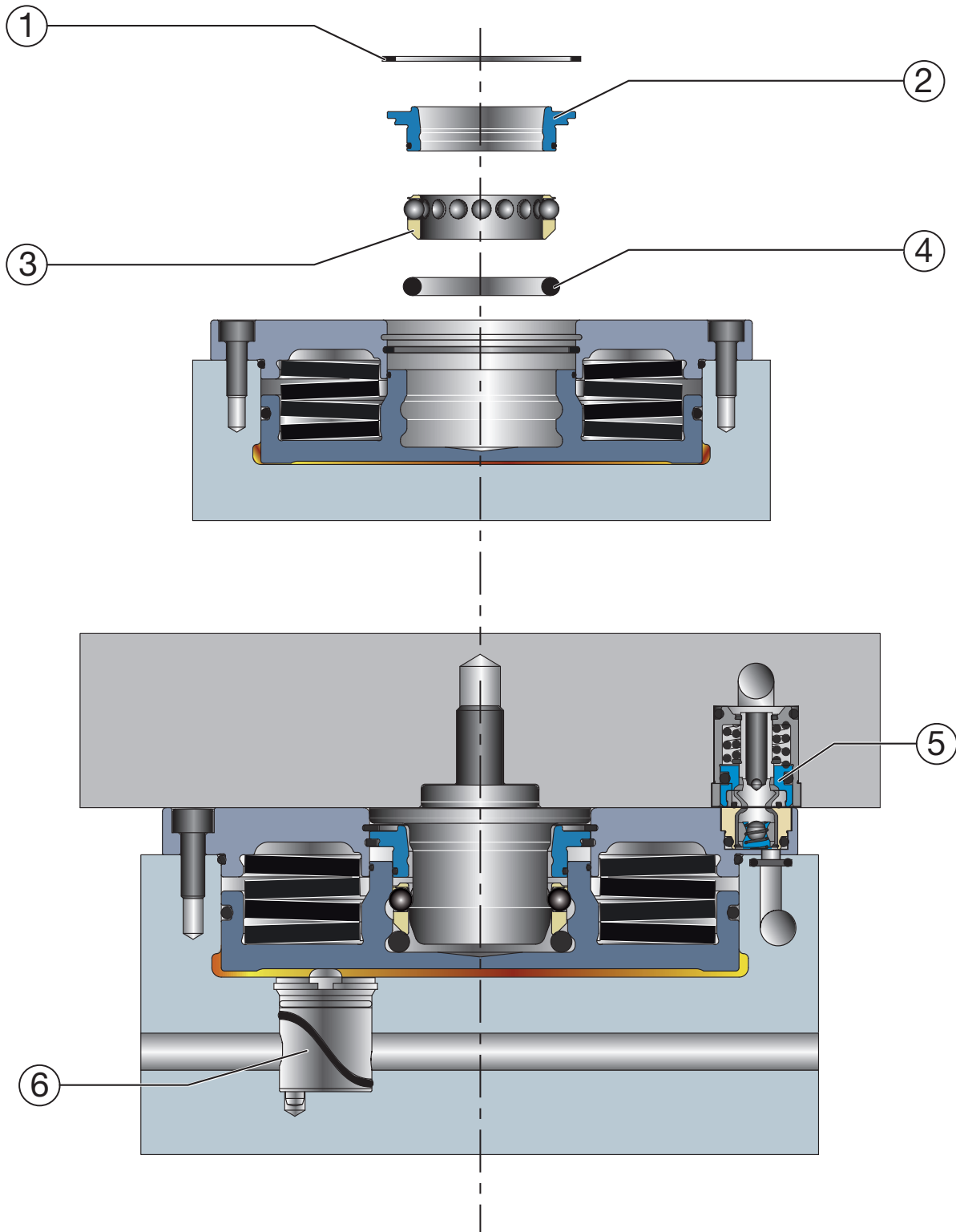

Well thought out solutions - reliable clamping for a very wide range of tasks

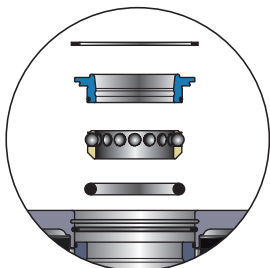

Simple cleaning

During machining, soiling of the clamping system over the long term is inevitable. For this reason ease of cleaning is very important.

On SPEEDY classic the retaining ring (2), ball cage (3) and O-ring (4) can be straightforwardly taken out after removing the locking ring (1), and then cleaned and re-fitted. This feature simplifies maintenance and provides the shortest possible downtimes.

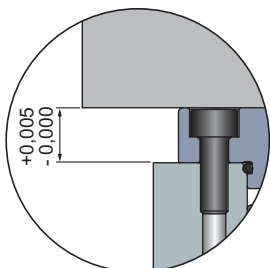

Precise contact

Very high accuracy to reduce tolerance errors (bearing plate thickness manufactured to within 5 µm).

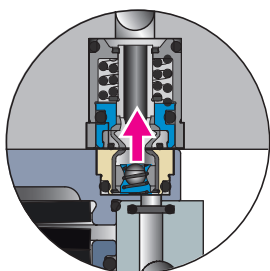

Integrated media ducts

For carrying media, e.g. oil, water etc. if required SPEEDY classic is equipped with integrated media ducts (5). The ducts are positioned and coupled automatically during clamping.

In this way, e.g., clamping devices fitted to the machine pallets can be supplied with power (hydraulic, pneumatic etc.). The coupling force is applied by the SPEEDY - straightforward handling, the pallet is fully automatically positioned, clamped and coupled (for more information see page 6.2).

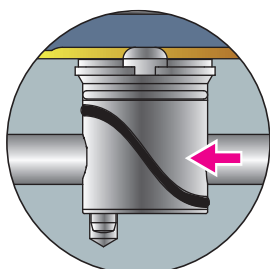

Clamping check

For safety reasons, a clamping check is strongly recommended on all machines that rotate at high speeds. For this purpose SPEEDY classic can be equipped with a mechanical clamp control valve (6).

The evaluation of the clamping check can be integrated directly in the machine control system. Existing machines can also be upgraded using an appropriate hydraulic unit and suitable control system. Your STARK partner will be pleased to provide you with information on the optimal solution (for more information see page 6.2).

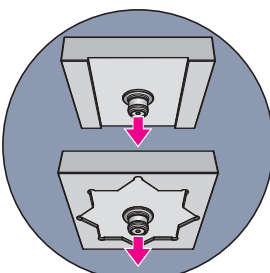

Position-orientated single mounting

On the usage of a square fast closing clamp the pallet is positioned and clamped in a specific orientation even on single mounting due to the square shape.

The system is characterised by high repeat accuracy, the possibility of simple divisions and easy cleaning.



Technical data - transparency from the start

		STANDARD	TORNADO	TWISTER
Maintenance interval, spring pack		40.000	40.000	40.000
Insertion force ¹	[N]	20.000	20.000	20.000
Retention force ²	[N]	38.000	38.000	38.000
Release pressure	[bar]	35-40	35-40	35-40
Max. pressure	[bar]	40	40	40
Lifting force at max.	[N]	10.000	10.000	10.000
Lateral forces max. allowed	[N]	9.000	9.000	9.000
Tilting torque	[Nm]	1.000	1.000	1.000
Twisting torque *	[Nm]	800	800	800
Oil volume	[cm ³]	38	38	38
Operating temperature	[°C]	10-80	10-80	10-80
Min. clamping time allowed	[s]	ca. 2	ca. 2	ca. 2
Min. release time allowed	[s]	ca. 2	ca. 2	ca. 2
Radial pre-positioning ³	[mm]	± 2,5	± 2,5	± 2,5
Max. axial pre-positioning automated loading	[mm]	- 0,3	- 0,3	- 0,3
Repeatability ⁴	[mm]	< 0,005	< 0,005	< 0,005
System accuracy ⁵	[mm]	< 0,01 **	< 0,01 **	< 0,01 **
Weight	[kg]	ca. 5	ca. 5	ca. 5

* Only on square version

** With appropriate design and adjustments, accuracies in the μ-range are possible.

¹ Insertion force

The insertion force (pre-load on the spring pack) refers to the load up to which the zero point is guaranteed. The insertion force stated must not be exceeded,

² Retention force

Retention force refers to the max. overload up to which the nipple will continue to be retained, but the zero point has already been left (designed for M10 screw).

³ Radial pre-positioning

The loading device must have play in the case of automated handling.

⁴ Repeatability

Repeatability generally refers to the accuracy with which the same pallet is positioned on changing on the same interface.

⁵ System accuracy

System accuracy refers to the accuracy resulting from changing several pallets, e.g. on different machines.

Tilting torque calculation example

Profit from our specialist competence

**Example:**

Fast closing clamp plate 4x SPEEDY classic 2 with 400 x 400 spacing and max. feed force of 10 kN with distance of 1000 mm.

Question:

Due to the predominance of roughing work, the system is to be checked for double safety. Are the insertion force, number of fast closing clamps and the selected spacing right for this application?

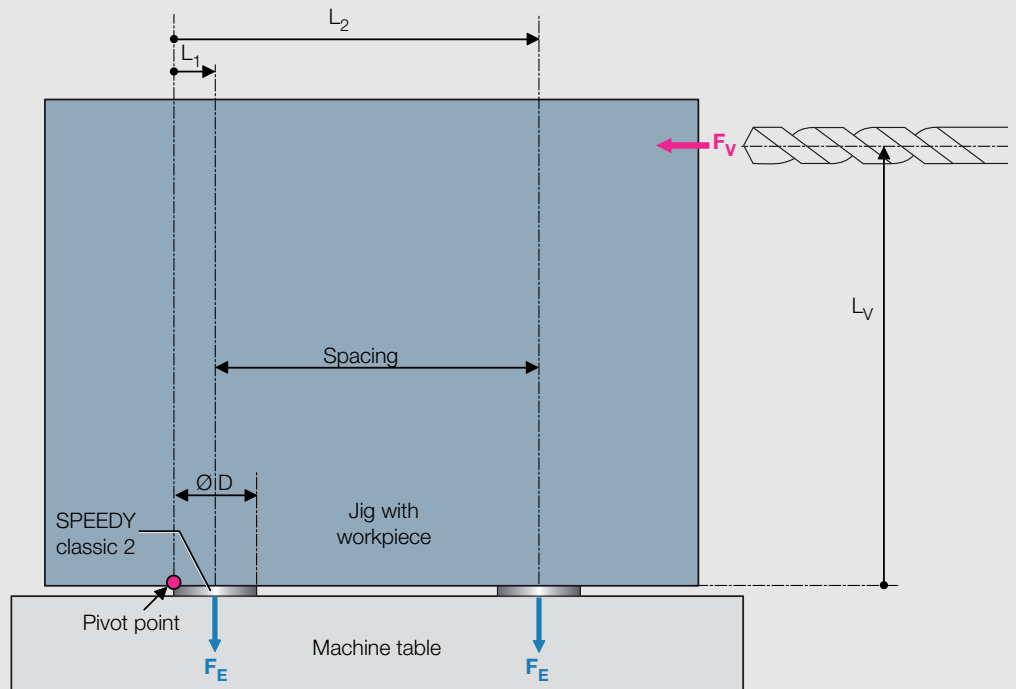
**Solution:**

$$M_E > 2 \times M_V ?$$

$$M_V = F_V \times L_V = 10.000 \text{ N} \times 1,0 \text{ m}$$

$$M_V = \mathbf{10.000 \text{ Nm}}$$

$$M_E = 2 \times (F_E \times L_1) + 2 \times (F_E \times L_2)$$

$$M_E = 2 \times F_E \times (L_1 + L_2)$$

$$L_1 = \text{ØD} / 2$$

$$L_2 = \text{ØD} / 2 + \text{Spacing}$$

$$L_1 + L_2 = \text{ØD} + \text{Spacing}$$

$$L_1 + L_2 = 0,135 \text{ m} + 0,40 \text{ m} = 0,535 \text{ m}$$

$$M_E = 2 \times F_E \times (L_1 + L_2) = 2 \times 20.000 \text{ N} \times 0,535 \text{ m}$$

$$M_E = \mathbf{21.400 \text{ Nm}}$$

$$M_E / M_V > 2 ?$$

$$M_E / M_V = 21.400 \text{ Nm} / 10.000 \text{ N}$$

$$M_E / M_V = \mathbf{2,14 > 2}$$

With this design, safety by around a factor of two is provided.

(All dimensions to be entered in SI units (metres, Newtons))

M_V : Moment from feed force

M_E : Moment from insertion force

F_V : Feed force (10.000 N)

F_E : Insertion force (20.000 N)

Spacing = 400 mm = 0,40 m

Ø D: 135 mm = 0,135 m

L_V : 1.000 mm = 1,0 m

Flush Mount

1

For direct installation in machine pallets, plates, angles, cubes, mounting towers or swivelling yokes
SPEEDY classic 2 Flush Mount is the proven zero point clamping system.

High quality tool steel ensures accuracy and robustness even under extreme conditions.

SPEEDY classic 2 Flush Mount has options for every application:

- Integrated media ducts
- Mount control (quality)
- Clamp check (safety)
- Optimised blow-out ducts
- Coolant drainage
- Modular structure
- Square shape for single mounting

*Top quality in the
smallest space!*





The compact zero point mounting solution for the highest requirements:

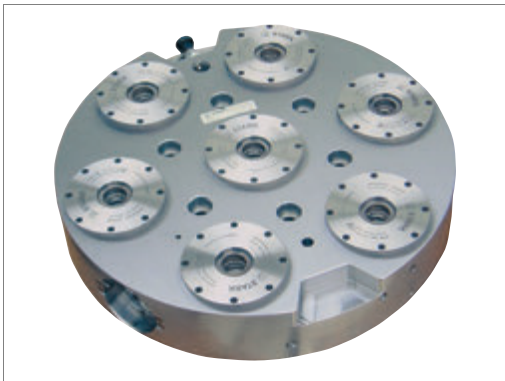

SPEEDY classic 2 fast closing clamps fitted in round plate, with external hydraulic connection

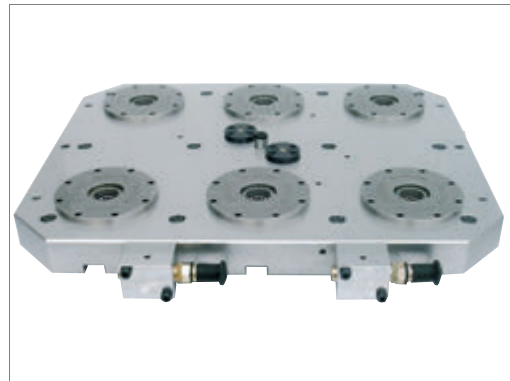

SPEEDY classic 2 fast closing clamps fitted in plate, with external hydraulic connection



SPEEDY classic 2 fast closing clamps fitted in plate, with external hydraulic connection

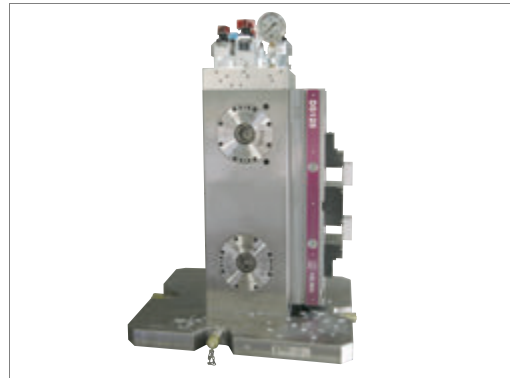

SPEEDY classic 2 fast closing clamps fitting in mounting tower

STANDARD

- Flush Mount
- Round

**Characteristics:**

Flush Mount fast closing clamp made of high quality tool steel.

Due to low height little space needed (can be installed even from plate thickness of 35 mm).

Is clamped mechanically and released hydraulically.

Application:

For flush mounting in machine pallets, plates, angles, cubes, towers and swivelling yokes.

Can be used for all common machining tasks such as milling, turning (note information in section "Clamp control valve" on page 6.9), grinding, eroding as well as on test stands for mounting devices.

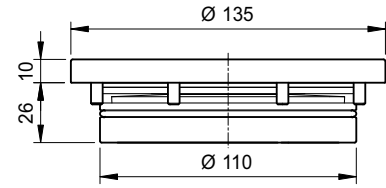

Z 804 452

Order no.	Retention force	Insertion force	Hydr. pressure to release	Weight	Data sheet
804 452	38,000 N	20,000 N	35-40 bar	2.40 kg	D020, D032

Fastening screws included with the items supplied. For mounting and service accessories, see section 7.

**Practical example**

SPEEDY classic 2 STANDARD round fitted in plate with matched fastening and positioning bores.



STANDARD

- Flush Mount
- Square



Characteristics:

Flush Mount fast closing clamp made of high quality tool steel.

Due to low height little space needed (can be installed even from plate thickness of 35 mm).

Is clamped mechanically and released hydraulically.

Due to the square shape the pallet is positioned and clamped in a specific orientation even on single mounting.

Application:

For single mounting, 5-axis machining and simple divisions. Can also be used mixed with round fast closing clamps.

For flush mounting in machine pallets, plates, angles, cubes, towers and swivelling yokes.

Can be used for all common machining tasks such as milling, turning (note information in section "Clamp control valve" on page 6.9), grinding, eroding as well as on test stands for mounting devices.

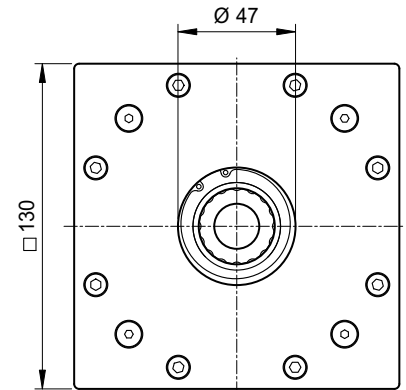
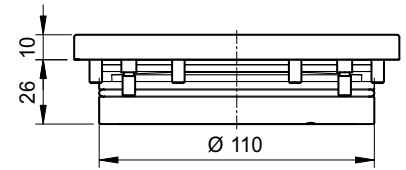

Z 804 453

Order no.	Retention force	Insertion force	Hydr. pressure to release	Weight	Data sheet
804 453	38,000 N	20,000 N	35-40 bar	2.50 kg	D001, D021

Fastening screws and precision collar bolts included in the items supplied. For mounting and service accessories, see section 7.



Application example

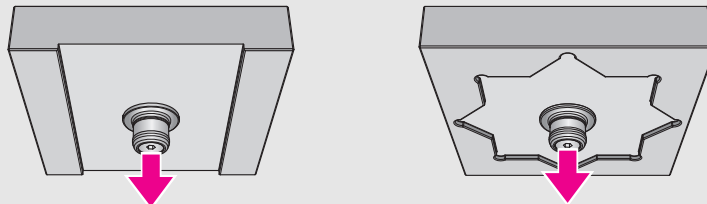

Due to special cut-outs, several clamping positions can be realised with one and the same pallet using square fast closing clamps.





STANDARD

- Flush Mount
- Round
- Media ducts



Characteristics:

Flush Mounting fast closing clamp made of high quality tool steel with media ducts.

Due to low height little space needed.

Is clamped mechanically and released hydraulically.

For all clamping situations in which hydraulics, pneumatics, emulsion or other media must be fed through the pallet.

Application:

For machining centres with media ducts on the machine table, for hydraulic and pneumatic clamping devices.

Can be combined as required with SPEEDY classic 2 without media ducts or square SPEEDY classic 2.

For flush mounting in machine pallets, plates, angles, cubes, towers and swivelling yokes.

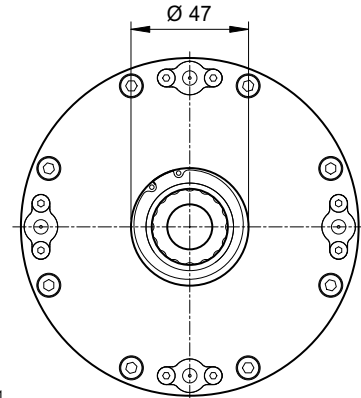
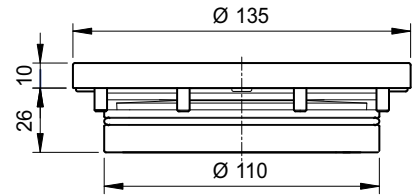

Z 704 321

Order no.	Retention force	Insertion force	Pos. and number of the media ducts	Max. perm. pressure for media ducts	Weight	Data sheet no.
704 321	38,000 N	20,000 N	1	200 bar	2.40 kg	D020, D021
704 322	38,000 N	20,000 N	2	200 bar	2.40 kg	D020, D021
704 323	38,000 N	20,000 N	3	200 bar	2.40 kg	D020, D021
704 324	38,000 N	20,000 N	4	200 bar	2.40 kg	D020, D021

Fastening screws included with the items supplied. For mounting and service accessories, see section 7.

For detailed information on the media ducts, see section 6 "media ducts".



Application example

SPEEDY classic 2 with one media duct

SPEEDY classic 2 with two media ducts

SPEEDY classic 2 with three media ducts

SPEEDY classic 2 with four media ducts

- 1) Compressed air
- 2) Feed 1
- 3) Return 1
- 4) Feed 2
- 5) Return 2

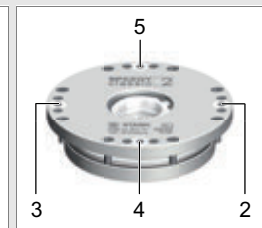
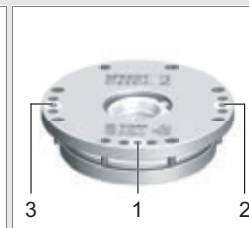
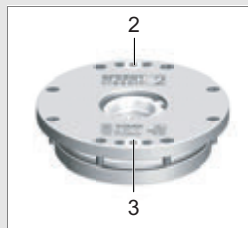

Note:

The sum of the axial forces on the media ducts acts against the SPEEDY's insertion force. Note technical data on page 6.2.



TORNADO

- Flush Mount
- Round
- Raised supports
- Blow-out ducts



Characteristics:

Flush Mount fast closing clamp made of high quality tool steel with raised supports and blow-out ducts.

Due to low height little space needed.

Is clamped mechanically and released hydraulically.

Intelligent blow-out system for cleaning the raised supports and the precision bore. Mount control via differential pressure, blocking air possible.

Application:

For flush mounting in machine pallets, plates, angles, cubes, swivelling yokes and mounting towers.

For partial automation, reduces the cleaning effort.

Can be used for all common machining tasks such as milling, turning (note information in section "Clamp control valve" on page 6.9), grinding, eroding as well as on test stands for mounting devices.

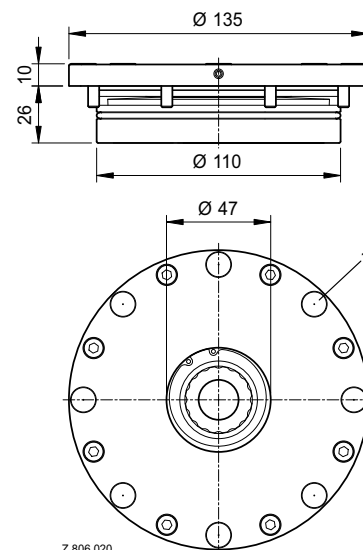

1) Raised supports with blow-out ducts

Order no.	Retention force	Insertion force	Hydr. pressure to release	Weight	Data sheet
806 020	38,000 N	20,000 N	35-40 bar	2.40 kg	D016

Fastening screws included with the items supplied. For mounting and service accessories, see section 7.

TORNADO

- Flush Mount
- Square
- Raised supports
- Blow-out ducts



Characteristics:

Flush Mount fast closing clamp made of high quality tool steel with raised supports and blow-out ducts. Bearing surfaces are kept clean as protection against swarf.

Due to low height little space needed.

Is clamped mechanically and released hydraulically.

Intelligent blow-out system for cleaning the raised supports and the precision bore. Mount control via differential pressure, blocking air possible.

Due to the square shape the pallet is positioned and clamped in a specific orientation even on single mounting.

Application:

For single mounting, 5-axis machining and simple divisions. Can also be used mixed with round fast closing clamps.

For partial automation, reduces the cleaning effort.

For flush mounting in machine pallets, plates, angles, cubes and swivelling yokes.

Can be used for all common machining tasks such as milling, turning (note information in section "Clamp control valve" on page 6.9), grinding, eroding as well as on test stands for mounting devices.

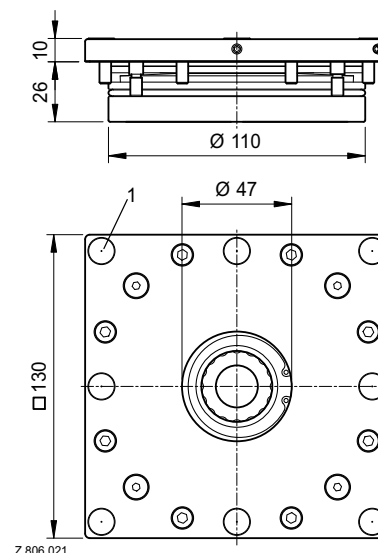

1) Raised supports with blow-out ducts

Order no.	Retention force	Insertion force	Hydr. pressure to release	Weight	Data sheet
806 021	38,000 N	20,000 N	35-40 bar	2.40 kg	D003

Fastening screws and precision collar bolts included in the items supplied. For mounting and service accessories, see section 7.



TORNADO

- Flush Mount
- Round
- Raised supports
- Blow-out ducts
- Coolant drainage



Characteristics:

Flush Mount fast closing clamp made of high quality tool steel with raised supports and blow-out ducts. Bearing surfaces are kept clean as protection against swarf.

Coolant drain through centre bore. Due to low height little space needed.

Is clamped mechanically and released hydraulically.

Intelligent blow-out system for cleaning the raised supports and the precision bore. Mount control via differential pressure, blocking air possible.

Application:

For partial automation, reduces the cleaning effort.

For flush mounting in machine pallets, plates, angles, cubes and swivelling yokes.

Can be used for all common machining tasks such as milling, turning (note information in section "Clamp control valve" on page 6.9), grinding, eroding as well as on test stands for mounting devices.

Especially for vertical eroding machines, flushing the centre bore.

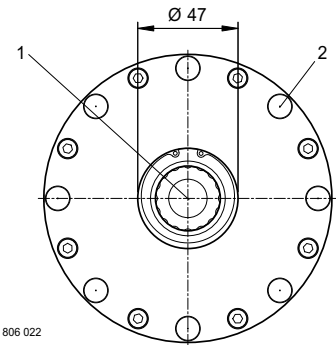
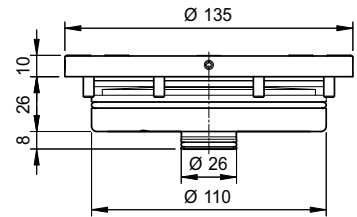

Z 806 022

- 1) Coolant drainage
- 2) Raised supports with blow-out ducts

Order no.	Retention force	Insertion force	Hydr. pressure to release	Weight	Data sheet
806 022	38,000 N	20,000 N	35-40 bar	2.40 kg	D015

Fastening screws included with the items supplied. For mounting and service accessories, see section 7.

TORNADO

- Flush Mount
- Square
- Raised supports
- Blow-out ducts
- Coolant drainage



Characteristics:

Flush Mount fast closing clamp made of high quality tool steel with raised supports and blow-out ducts. Bearing surfaces are kept clean as protection against swarf.

Coolant drain through centre bore. Due to low height little space needed.

Is clamped mechanically and released hydraulically.

Intelligent blow-out system for cleaning the raised supports and the precision bore. Mount control via differential pressure, blocking air possible.

Due to the square shape the pallet is clamped and positioned in a specific orientation even on single mounting.

Application:

For single mounting, 5-axis machining and simple divisions.

Can also be mixed with round fast closing clamps.

For partial automation, reduces the cleaning effort.

For flush mounting in machine pallets, plates, angles, cubes and swivelling yokes.

Can be used for all common machining tasks such as milling, turning (note information in section "Clamp control valve" on page 6.9), grinding, eroding as well as on test stands for mounting devices.

Especially for vertical eroding machines, flushing the centre bore.

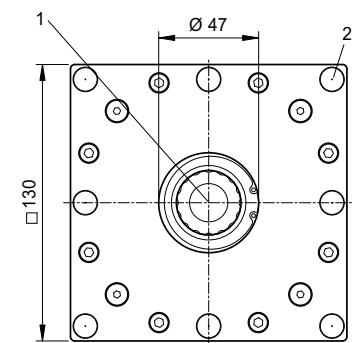
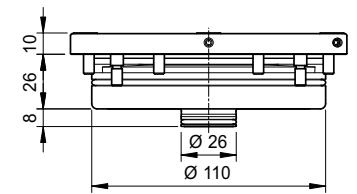

Z 806 023

- 1) Coolant drainage
- 2) Raised supports with blow-out ducts

Order no.	Retention force	Insertion force	Hydr. pressure to release	Weight	Data sheet
806 023	38,000 N	20,000 N	35-40 bar	2.40 kg	D013

Fastening screws and precision collar bolts included in the items supplied. For mounting and service accessories, see section 7.



TWISTER

- Flush Mount
- Round
- Raised supports
- Blow-out ducts



for
AUTOMATION!

Characteristics:

Flush Mount fast closing clamp made of high quality tool steel with raised supports and blow-out ducts.

Due to low height little space needed.

Is clamped mechanically and released hydraulically.

Intelligent blow-out system for cleaning the raised supports and the precision bore. Mount control via differential pressure, blocking air possible.

Due to extending duct particularly effective cleaning of the raised supports. Due to 3 mm high raised supports, not possible to trap swarf.

Application:

For high accuracy during automatic loading.

For flush mounting in machine pallets, plates, angles, cubes and swivelling yokes.

Can be used for all common machining tasks such as milling, turning (note information in section "Clamp control valve" on page 6.9), grinding, eroding as well as on test stands for mounting devices.

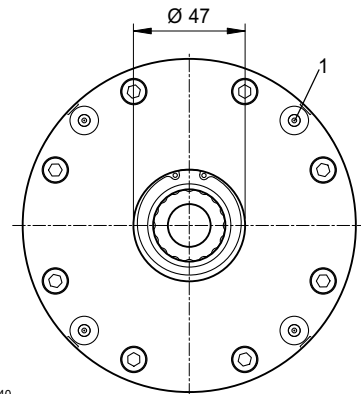
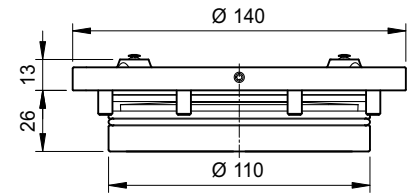

Z 804 540

1) Raised supports with intelligent blow-out system

Order no.	Retention force	Insertion force	Hydr. pressure to release	Weight	Data sheet
804 540	38,000 N	20,000 N	35-40 bar	2.50 kg	D016

Fastening screws included with the items supplied. For mounting and service accessories, see section 7.



Recommended configuration:

SPEEDY classic TWISTER with hardened bearing plate

Sectional view

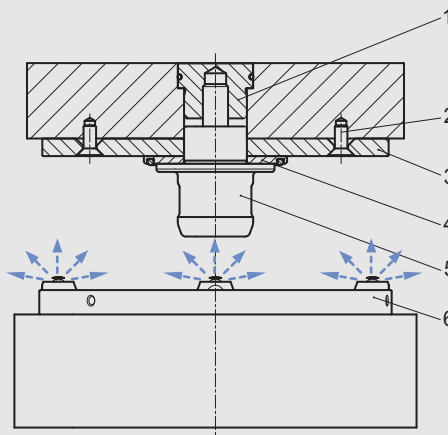

- 1) Nipple fastening
- 2) Countersunk screw DIN 7991
- 3) Hardened bearing plate
- 4) Spacer washer
- 5) Retractable nipple
- 6) SPEEDY Twister

Practical example

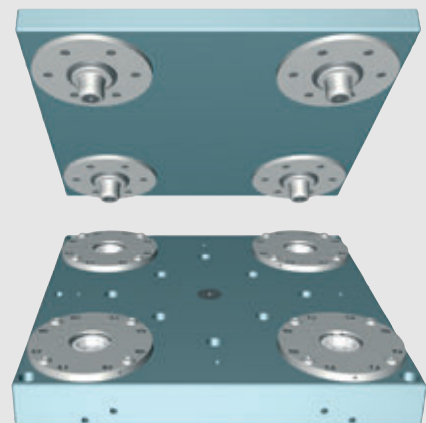

SPEEDY classic 2 TWISTER fast closing clamps, fitted in plate

The spacer washer (4) is imperative for each SPEEDY classic 2 TWISTER and must be fitted to each retractable nipple!



STANDARD

- Module
- Round

**Characteristics:**

Module made of high quality tool steel.

Is clamped mechanically and released hydraulically.

Application:

For flush mounting in machine pallets, plates, angles, cubes, towers and swivelling yokes.

If plates or machine pallets cannot be pressurised, the cylinders can be connected using pipework, pneumatic and hydraulic connection possible either via flange or through the base.

Simple installation in any position possible. Self-contained system, can also be used in through bores.

Can be used for all common machining tasks such as milling, turning (clamp control valve imperative, note information in section "Clamp control valve" on page 6.9), grinding, eroding as well as on test stands for mounting devices.

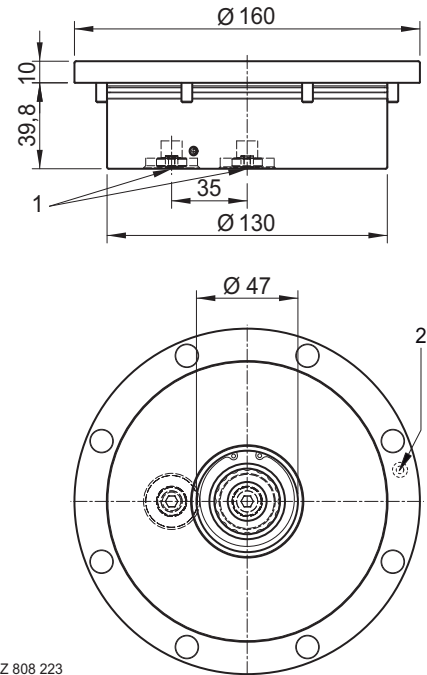

Z 808 223

- 1) Base connection variant G1/8"
- 2) Flange connection variant

Order no.	Retention force	Insertion force	Hydr. pressure to release	Hydraulic connection	Weight	Data sheet
808 223	38,000 N	20,000 N	35-40 bar	Base	2.40 kg	D009
808 224	38,000 N	20,000 N	35-40 bar	Base + flange	2.40 kg	D008

Fastening screws and screw covers included in the items supplied. For mounting and service accessories, see section 7.



TORNADO

- Module
- Round
- Raised supports
- Blow-out ducts



Characteristics:

Module made of high quality tool steel with raised supports and blow-out ducts.

Intelligent blow-out system for cleaning the raised supports and the precision bore.

Is clamped mechanically and released hydraulically.

Application:

If plates or machine pallets cannot be sealed, the cylinders can be connected using pipework, pneumatic and hydraulic connection possible either via flange or through the base.

Simple installation in any position possible. Self-contained system, can also be used in through bores.

Can be used for all common machining tasks such as milling, turning (clamp control valve imperative, note information in section "Clamp control valve" on page 6.9), grinding, eroding as well as on test stands for mounting devices.

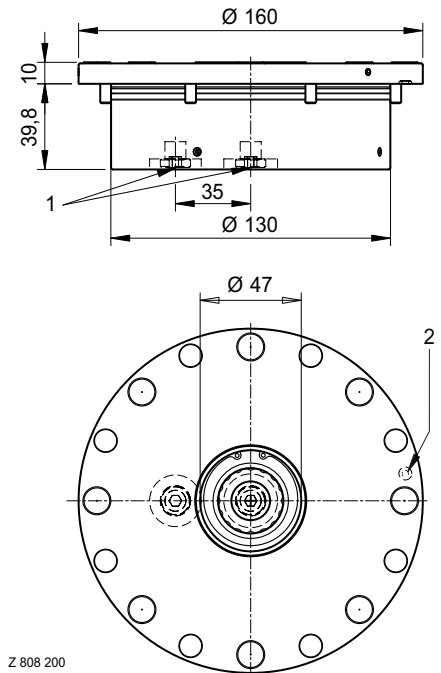

Z 808 200

- 1) Base connection variant G1/8"
2) Flange connection variant

Order no.	Retention force	Insertion force	Hydr. pressure to release	Hydraulic connection	Air connection	Weight	Data sheet
808 200	38,000 N	20,000 N	35-40 bar	Base + flange	Flange	2.40 kg	D008

Fastening screws and screw covers included in the items supplied. For mounting and service accessories, see section 7.



Sectional view

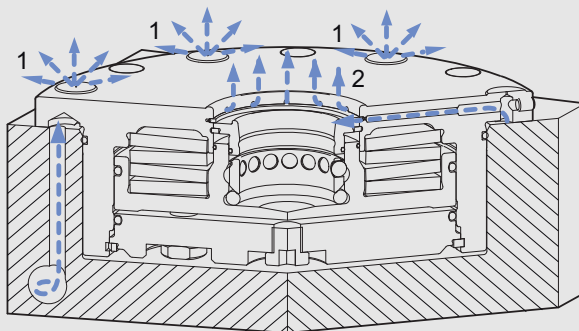

- 1) Raised support blow-out ducts
2) Centre blow-out ducts

Blowing out is performed directly at the bearing surfaces and at the precision diameter.

Detail view



Openings for centre blow-out ducts



Surface Mount

2

SPEEDY classic 2 Surface Mount is the zero point clamping system that fits on every machine.

With SPEEDY classic 2 Surface Mount you can optimise your older machinery and increase your productivity without major investment.

Due to its low weight, the effect on dynamic movements on the machine table is minimal.

*Upgrade now -
it is never too late for a
zero clamping system!*



Every production machine deserves to have its own SPEEDY zero point clamping system:

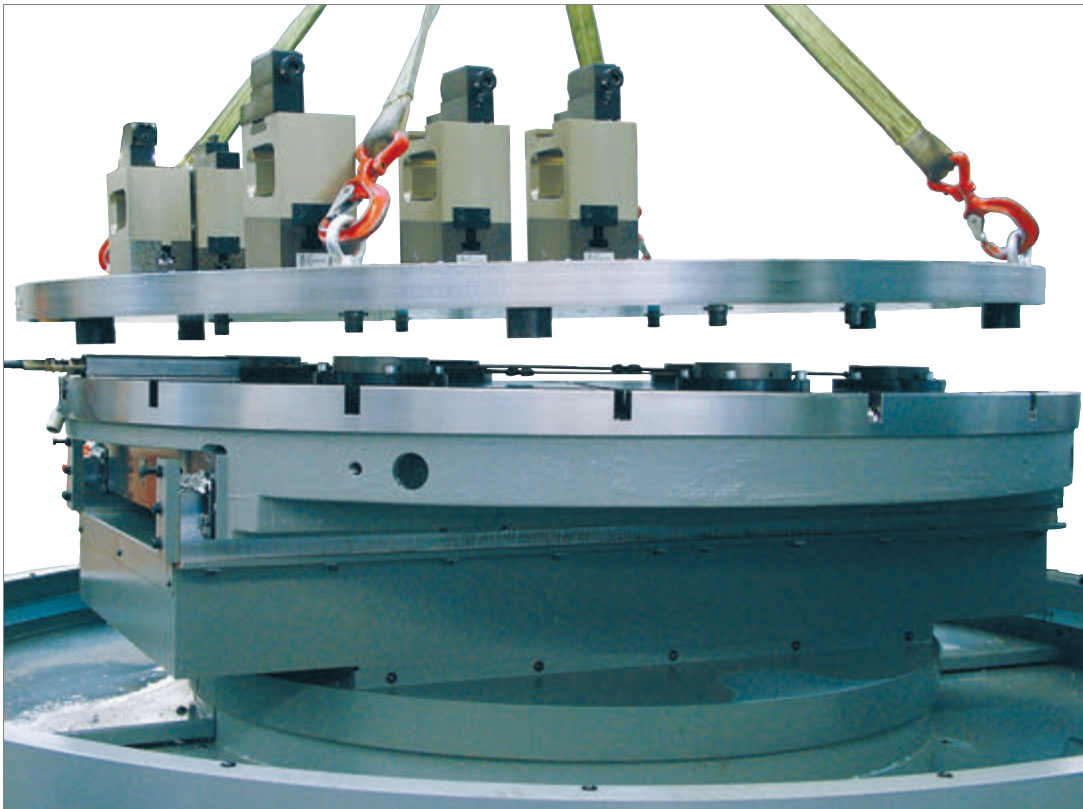

SPEEDY classic 2 fast closing clamp fitted to a round plate with pipework

STANDARD

- Surface Mount
- Round



Characteristics:

Surface Mount fast closing clamp made of high quality tool steel. Is clamped mechanically and released hydraulically.

Variable spacing on usage of hydraulic hoses.

In comparison to a fast closing clamp plate, low machine table load.

Application:

For surface mounting on machine pallets, plates, angles, cubes, towers and swivelling yokes.

Can be used for all common machining tasks such as milling, turning, grinding, eroding as well as on test stands for mounting devices.

Optional with centring shank for centring on a perforated plate.

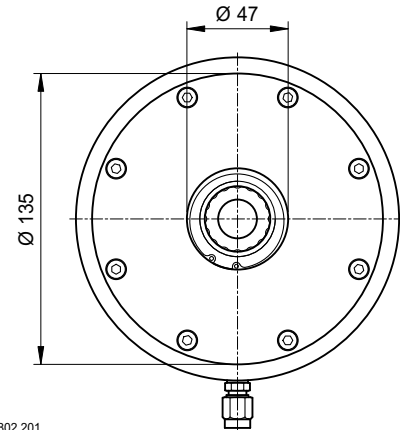
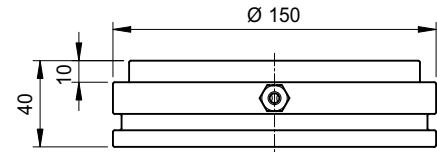

Z 802 201

Order no.	Retention force	Insertion force	Hydr. pressure to release	Weight
802 201	38,000 N	20,000 N	35-40 bar	4.40 kg

Hydraulic fitting Ø6 1/8" included with the items supplied.

STANDARD

- Surface Mount
- Square



Characteristics:

Surface Mount fast closing clamp made of high quality tool steel. Is clamped mechanically and released hydraulically.

Due to the square shape the pallet is positioned in a specific orientation even on single mounting.

Variable spacing on usage of hydraulic hoses.

In comparison to a fast closing clamp plate, low machine table load.

Application:

For surface mounting on machine pallets, plates, angles, cubes, towers and swivelling yokes.

Can be used for all common machining tasks such as milling, turning, grinding, eroding as well as on test stands for mounting devices.

For single mounting and simple divisions. Can also be used mixed with round fast closing clamps.

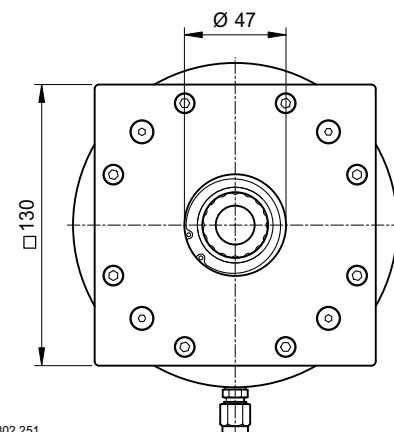
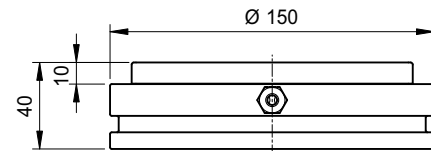

Z 802 251

Order no.	Retention force	Insertion force	Hydr. pressure to release	Weight
802 251	38,000 N	20,000 N	35-40 bar	4.50 kg

Hydraulic fitting Ø6 1/8" included with the items supplied.



STANDARD

- Surface Mount
- Round
- Centring shank



Characteristics:

Surface Mount fast closing clamp made of high quality tool steel. Is clamped mechanically and released hydraulically.

Variable spacing on usage of hydraulic hoses.

Centring shank with fit for precise positioning.

In comparison to a fast closing clamp plate, low machine table load.

Application:

For surface mounting on machine pallets, plates, angles, cubes, towers and swivelling yokes.

Can be used for all common machining tasks such as milling, turning, grinding, eroding as well as on test stands for mounting devices.

Optional with centring shank for centring on a perforated plate.

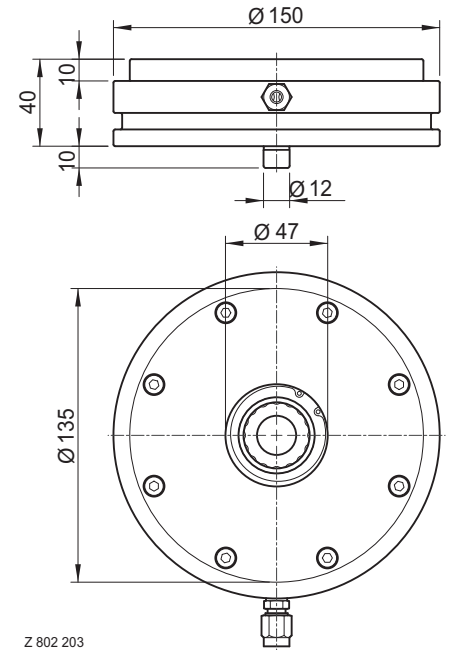

Z 802 203

Order no.	Retention force	Insertion force	Hydr. pressure to release	Weight
802 203	38,000 N	20,000 N	35-40 bar	4.40 kg

Hydraulic fitting Ø6 1/8" included with the items supplied.

STANDARD

- Surface Mount
- Square
- Centring shank



Characteristics:

Surface Mount fast closing clamp made of high quality tool steel. Is clamped mechanically and released hydraulically.

Due to the square shape the pallet is positioned in a specific orientation even on single mounting.

Variable spacing on usage of hydraulic hoses.

Centring shank with fit for precise positioning.

In comparison to a fast closing clamp plate, low machine table load.

Application:

For surface mounting on machine pallets, plates, angles, cubes, towers and swivelling yokes.

Can be used for all common machining tasks such as milling, turning, grinding, eroding as well as on test stands for mounting devices.

For single mounting and simple divisions. Can also be used mixed with round fast closing clamps.

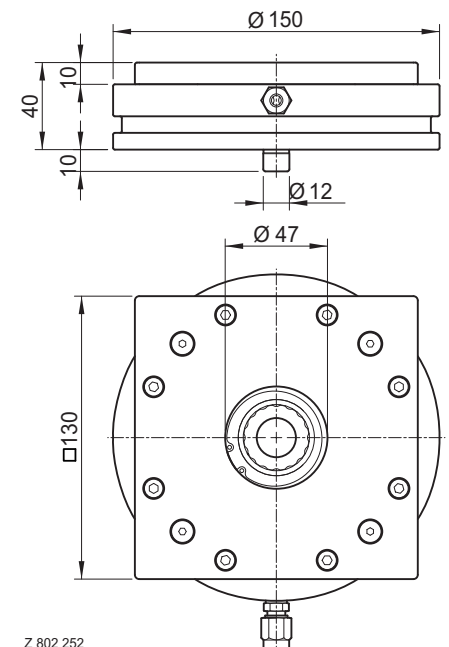

Z 802 252

Order no.	Retention force	Insertion force	Hydr. pressure to release	Weight
802 252	38,000 N	20,000 N	35-40 bar	4.50 kg

Hydraulic fitting Ø6 1/8" included with the items supplied.





SET 4

• Surface Mount



Order no.	Description	Pcs.	Spacing *	Weight
802 210	SET 4 A, comprising:		320	
804 411	Pressure booster	1		8.80 kg
802 201	Fast closing clamp SPEEDY classic 2Insertion force 20,000 N	4		4.40 kg
804 456	Fixing clamp	8		0.60 kg
804 470	Retractable nipple	8		0.16 kg
804 370	Connection block	1		0.20 kg
804 254	Retractable nipple key	1		0.08 kg
802 211	SET 4 B (as for set A, however without pressure booster)		320	

* Incl. pipework and fittings for 320 spacing, additional pipes and fittings are available for other configurations (see from page 2.8)



Practical example

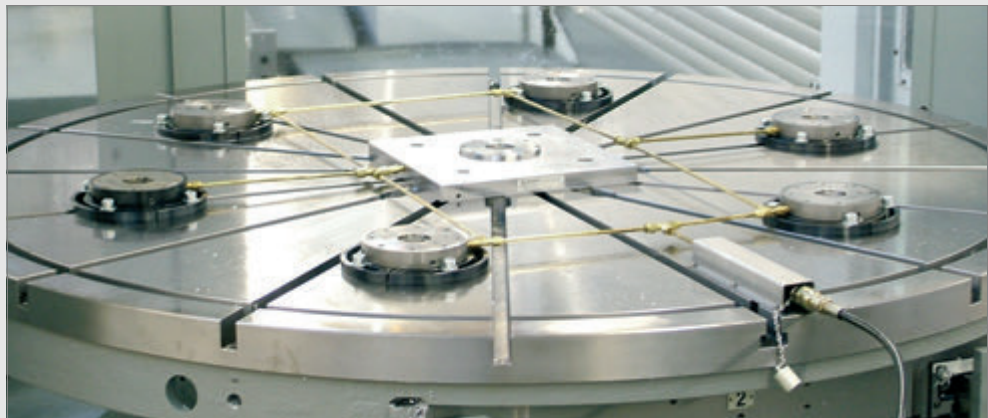

SPEEDY classic 2 Surface Mount with hydraulic pipework

SET 6

• Surface Mount



Order no.	Description	Pcs.	Spacing *	Weight
802 212	SET 6 A, comprising:		320	
804 411	Pressure booster	1		8.80 kg
802 201	Fast closing clamp SPEEDY classic 2Insertion force 20,000 N	6		4.40 kg
804 456	Fixing clamp	12		0.60 kg
804 470	Retractable nipple	12		0.16 kg
804 370	Connection block	1		0.20 kg
804 254	Retractable nipple key	1		0.08 kg
802 213	SET 6 B (as for set A, however without pressure booster)		320	

* Incl. pipework and fittings for 320 spacing, additional pipes and fittings are available for other configurations (see from page 2.8)



Fixing clamps for fastening the fast closing clamps

For fastening the fast closing clamps to the machine table, a range of three fixing clamps is available, these items can be combined as required.

Possible combinations:

Due to the special shapes of the fixing clamps, it is possible to fasten the fast closing clamps to any commonly available T groove table or perforated plates without problems.

Note:

Only stably fastened fast clamping cylinders can withstand the forces given. Pay attention to operating instructions!

For optimal fastening, three to four fastening screws are to be used per fast closing clamp.



Application example

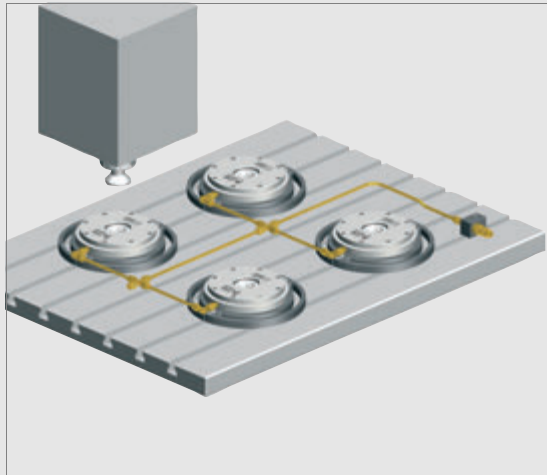

Position fast closing clamps and fasten using the fixing clamps.

Pay attention to symmetrical fastening. If possible, fasten fast closing clamps diagonally across the middle.

Pay attention to operating instructions.

Fixing clamp 1



Characteristics:

Fixing clamp for fastening the Surface Mount fast closing clamps.

Application:

For fastening SPEEDY classic 2 Surface Mount fast closing clamp.

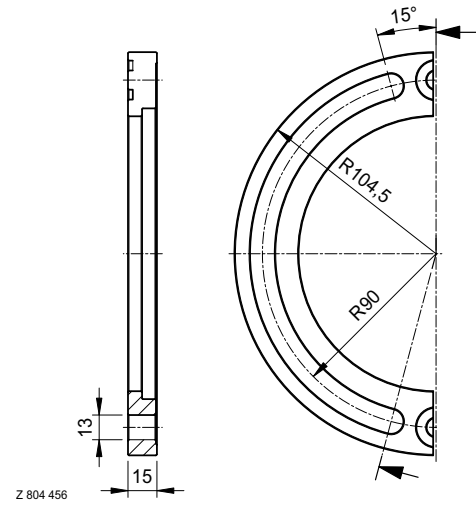

Order no.	Description	Weight
804 456	Fixing clamp form 1 for SPEEDY classic 2	0.60 kg

Fixing clamp 2



Characteristics:

Fixing clamp for fastening the Surface Mount fast closing clamps.

Application:

For fastening SPEEDY classic 2 Surface Mount fast closing clamp.

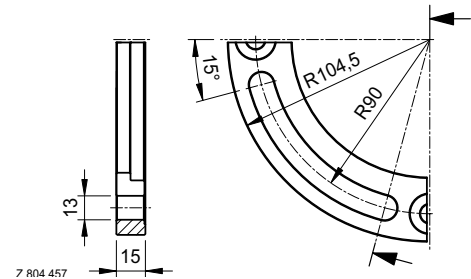

Order no.	Description	Weight
804 457	Fixing clamp form 2 for SPEEDY classic 2	0.30 kg

Fixing clamp 3



Characteristics:

Fixing clamp for fastening the Surface Mount fast closing clamps.

Application:

For fastening SPEEDY classic 2 Surface Mount fast closing clamp.

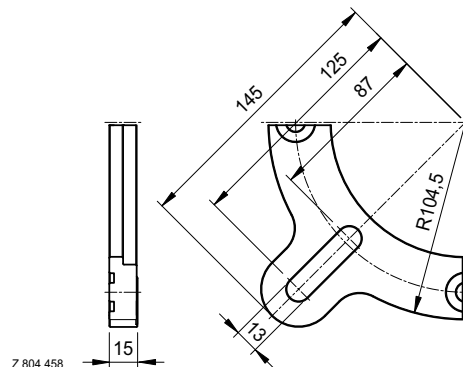

Order no.	Description	Weight
804 458	Fixing clamp form 3 for SPEEDY classic 2	0.30 kg



Fastening kit



Characteristics:

Fastening kit for fixing clamps.

Application:

For fastening the fixing clamps in T grooves.

Order no.	Description	Weight
931 059	Fastening screw M12x40 DIN 912	
938 023	Washer M12 DIN 125 A	
955 103	Groove nut M12x14 DIN 508	0.10 kg

Connecting ring



Characteristics:

Connecting ring for fixing clamps.

Application:

For connecting the fixing clamps together.

Order no.	Description	Weight
938 006	Connecting ring M10 DIN 125 A	0.01 kg

Positioning nipple



Characteristics:

Positioning nipple for mounting in a collet.

Application:

For quick, accurate positioning of the SPEEDY classic 2 fast closing clamps.

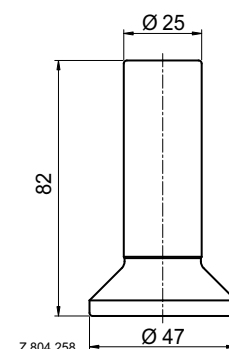

Order no.	Description	Weight
804 258	Positioning nipple for SPEEDY classic 2	0.30 kg



Application example



Positioning example based on a SPEEDY set plate



Hydraulic coupler

- SPEEDY side
- Self-sealing



Characteristics:

Self-sealing coupler

Application:

Coupling for fast closing clamp plates or connection block for pipework for the SPEEDY classic 2 Surface Mount fast closing clamps.

Particularly recommended for use in conjunction with pressure boosters (it is not necessary to re-fill the pressure booster).

Can be used wherever escaping oil must not enter the drilling emulsion and the coupling is frequently used.

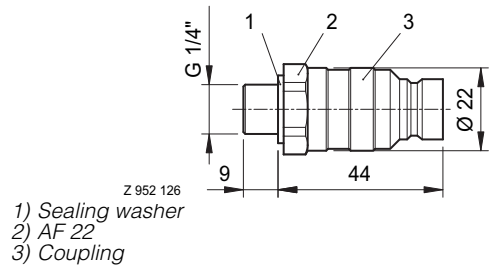

Order no.	Description	Max. pressure	Weight
952 126	Hydraulic coupler	300 bar	0.10 kg

Connection block with hydraulic coupler

- Self-sealing



Characteristics:

Connection block for hydraulic pipework.

Application:

Connection block for pipework for SPEEDY classic 2 Surface Mount fast closing systems.

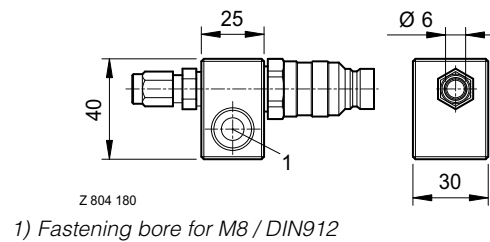

Order no.	Description	Max. pressure	Weight
804 180	Connection block for pipework, with self-sealing coupling, suitable for SPEEDY classic 2	100 bar	0.20 kg

Protective cap for hydraulic coupler included in the items supplied.

Hydraulic coupler

- Hose side
- Self-sealing



Characteristics:

Self-sealing hydraulic coupler for hydraulic pipework.

Application:

Self-sealing hydraulic coupler for hydraulic pipework for SPEEDY classic 2 Surface Mount fast closing clamps.

Order no.	Description	Max. pressure	Weight
952 177	Self-sealing hydraulic coupler for hydraulic pipework for SPEEDY classic 2, inside thread G1/4"	300 bar	0.20 kg





Hydraulic coupler

- SPEEDY side



Characteristics:

Coupler for connection block for hydraulic pipework.

Application:

Coupling for fast closing clamp plates or connection block for pipework for the SPEEDY classic 2 Surface Mount fast closing clamps.

- 1) Double nipple
- 2) Sealing washer
- 3) AF 18
- 4) AF 19
- 5) Coupling

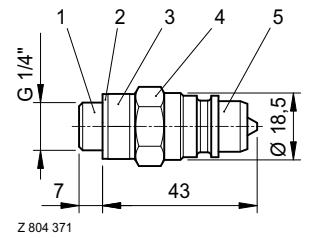

Order no.	Description	Max. pressure	Weight
804 371	Hydraulic coupler	700 bar	
804 372	Steel double nipple	500 bar	
804 395	Aluminium protective cap		0.10 kg

Connection block

- Can be screwed in place



Characteristics:

Connection block for hydraulic pipework.

Application:

Connection block for pipework for SPEEDY classic 2 Surface Mount fast closing systems.

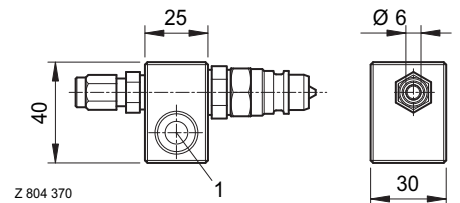

- 1) Fastening bore for M8 / DIN912

Order no.	Description	Max. pressure	Weight
804 370	Connection block for pipework suitable for SPEEDY classic 2	100 bar	0.20 kg

Protective cap for hydraulic coupler included in the items supplied.

Hydraulic coupler

- Hose side



Characteristics:

Hydraulic coupler for hydraulic pipework.

Application:

Hydraulic coupler for hydraulic pipework for SPEEDY classic 2 Surface Mount fast closing clamps.

Order no.	Description	Max. pressure	Weight
952 044	Hydraulic coupler for hydraulic pipework for SPEEDY classic 2, inside thread G1/4"	700 bar	0.20 kg

Fitting with male nipple



Characteristics:

Fitting with male nipple made of brass.

Application:

Fitting for SPEEDY classic 2 Surface Mount fast closing clamps.

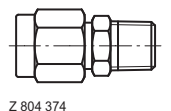

Z 804 374

Order no.	Description	Max. pressure	Weight
804 374	SO 41121-8-1/4" with reduced brass clamping ring Ø 6	100 bar	
804 375	SO 41121-6-1/8"	100 bar	0.26 kg



Straight fitting

Characteristics:

Straight fitting made of brass.

Application:

Fitting for pipework for SPEEDY classic 2 Surface Mount fast closing clamps.

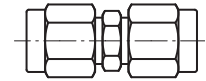

Z 804 379

Order no.	Description	Max. pressure	Weight
804 379	SO 41021-8 with reduced brass clamping ring Ø 6	100 bar	0.35 kg

Elbow fitting

Characteristics:

Elbow fitting made of brass.

Application:

Elbow fitting for pipework for SPEEDY classic 2 Surface Mount fast closing clamps.

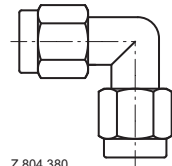

Z 804 380

Order no.	Description	Max. pressure	Weight
804 380	SO 42021-8 with reduced brass clamping ring Ø 6	100 bar	0.04 kg

T-fitting

Characteristics:

T-fitting made of brass.

Application:

T-fitting for pipework for SPEEDY classic 2 Surface Mount fast closing clamps.

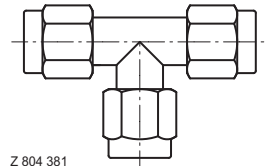

Z 804 381

Order no.	Description	Max. pressure	Weight
804 381	SO 43021-8 with reduced brass clamping ring Ø 6	100 bar	0.05 kg

Cross fitting

Characteristics:

Cross piece made of brass.

Application:

Cross fitting for pipework for SPEEDY classic 2 Surface Mount fast closing clamps.

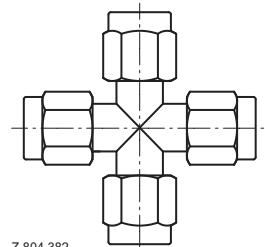

Z 804 382

Order no.	Description	Max. pressure	Weight
804 382	SO 44021-8 with reduced brass clamping ring Ø 6	100 bar	0.08 kg

Adjustable fitting

Characteristics:

Adjustable elbow made of brass.

Application:

Adjustable fitting for pipework for SPEEDY classic 2 Surface Mount fast closing clamps.

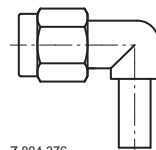

Z 804 376

Order no.	Description	Max. pressure	Weight
804 376	SO 42621-6-A6	100 bar	0.03 kg





Adjustable fitting T 90



Characteristics:

Adjustable T-fitting made of brass.

Application:

Adjustable fitting for pipework for SPEEDY classic 2 Surface Mount fast closing clamps.

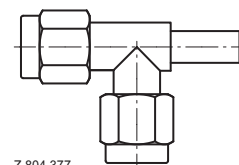

Z 804 377

Order no.	Description	Max. pressure	Weight
804 377	SO 43621-A6-6-6	100 bar	0.05 kg

Adjustable fitting T 180



Characteristics:

Adjustable T-fitting made of brass.

Application:

Adjustable fitting for pipework for SPEEDY classic 2 Surface Mount fast closing clamps.

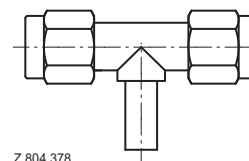

Z 804 378

Order no.	Description	Max. pressure	Weight
804 378	SO 43621-6-A6-6	100 bar	0.06 kg

Brass pipe for spacing as required



Characteristics:

Brass pipe Ø 6/4 mm.

Application:

For pipework for SPEEDY classic 2 Surface Mount fast closing clamps at spacing as required.

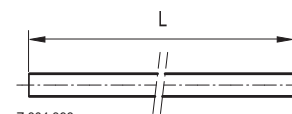

Z 804 398

Order no.	Description	L	Max. pressure*	Weight
804 398	Brass pipe Ø 6/4 mm	1000	80 bar	0.13 kg
804 399	Brass pipe Ø 6/4 mm	1500	80 bar	0.20 kg

*) Use steel pipe for higher pressures.

Shut-off valve



Characteristics:

Shut-off valve for installation in the pipework.

Application:

Shutting off individual clamping circuits.

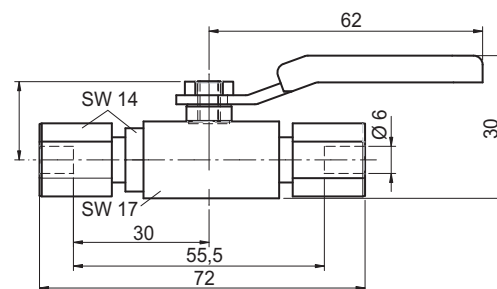

Z 999 104

Order no.	Description	Max. pressure	Weight
999 104	Shut-off valve with ball valve for pipework	64 bar	0.10 kg



Retractable nipple

3

The critical conflicts of stable clamping and the necessary movement for thermal expansion are ideally solved with three different retractable nipples.

Independent of the size of the pallet, you always have a fixed zero point also during machining. You can define where the retractable nipple with zero point is positioned.

*Precise positioning
for stable clamping*

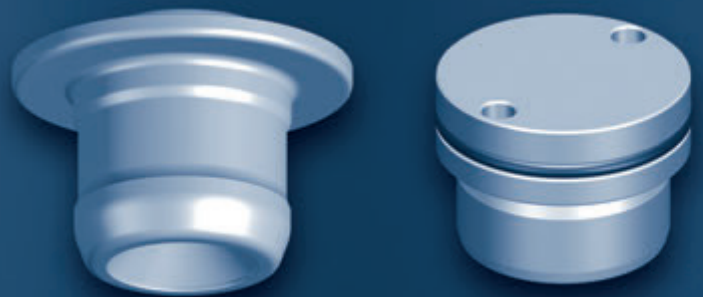



One thing is certain – the fixed zero point with SPEEDY retractable nipples:

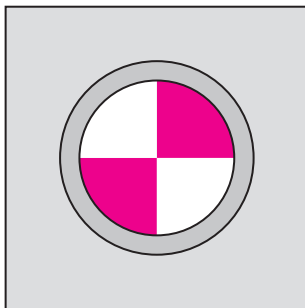

1) Retractable nipple with zero point

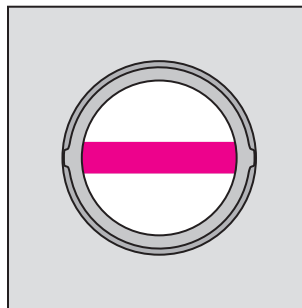

2) Retractable nipple with equaliser

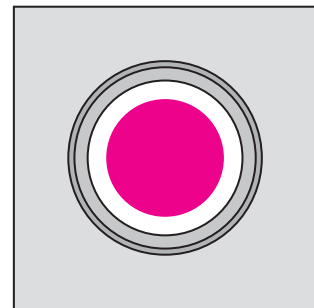

3) Retractable nipple

Retractable nipple with zero point in the middle of the pallet

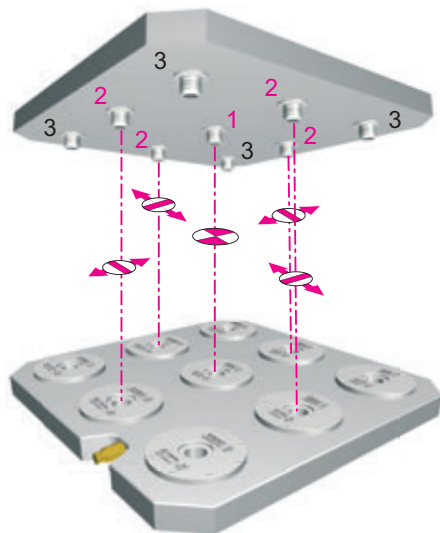

Retractable nipple with zero point at the corner of the pallet

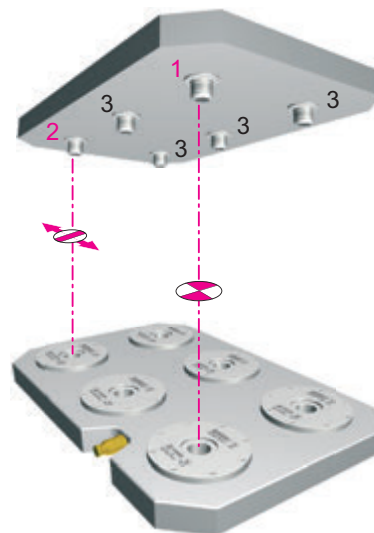



Retractable nipple

- with zero point



Characteristics:

Retractable nipple with zero point.

Application:

For positioning and clamping on machine pallets, machine vices, chucks, jigs, direct work-piece clamping.

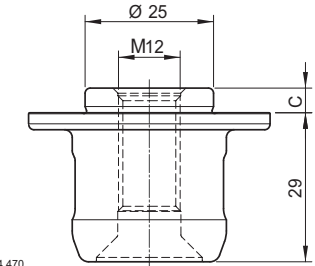
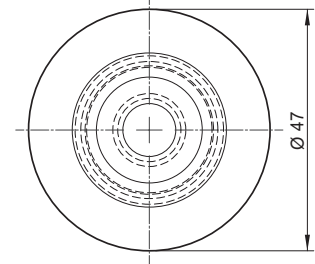

Z 804 470

Order no.	C	Screw grade	Tightening torque at the screw		Weight	Data sheet
			M10	M12		
804 470	4.8	min. 10.9	45 Nm	60 Nm	0.16 kg	D029
804 474	14.8	min. 10.9	45 Nm	60 Nm	0.16 kg	D029

Retractable nipple

- With equaliser



Characteristics:

Retractable nipple with equaliser on one axis.

Application:

On machine pallets, machine vices, chucks, jigs, direct workpiece clamping.

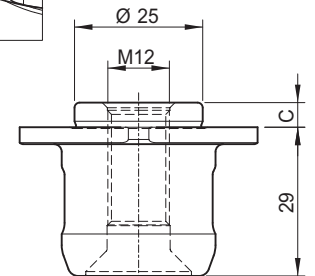
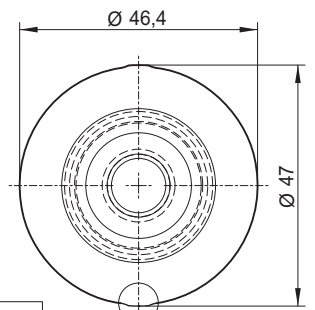

Z 804 471

Order no.	C	Screw grade	Tightening torque at the screw		Weight	Data sheet
			M10	M12		
804 471	4.8	min. 10.9	45 Nm	60 Nm	0.16 kg	D029
804 476	14.8	min. 10.9	45 Nm	60 Nm	0.16 kg	D029



Retractable nipple



Characteristics:

Retractable nipple without centring.

Application:

For secure clamping on machine pallets, machine vices, chucks, jigs, direct workpiece clamping.

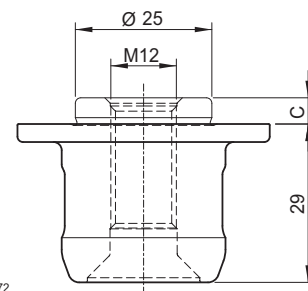
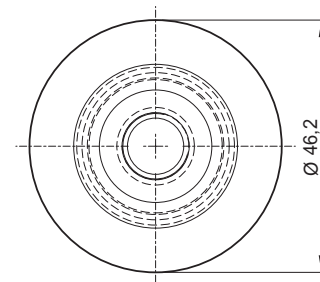

Z 804 472

Order no.	C	Screw grade	Tightening torque at the screw		Weight	Data sheet
			M10	M12		
804 472	4.8	min. 10.9	45 Nm	60 Nm	0.16 kg	D029
804 478	14.8	min. 10.9	45 Nm	60 Nm	0.16 kg	D029



Application example

Variant A

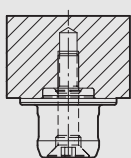

Variant B

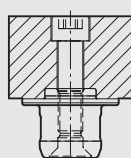

Variant C

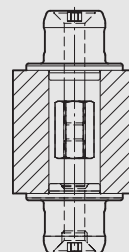

Variant D

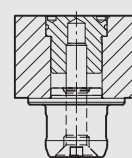

Variant E

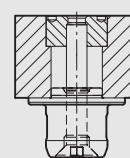

Variant A:

For applications in which nipple bores are not allowed on the surface of the pallet, or in case of direct workpiece clamping.

Variant B:

Simple nipple fastening from above, if high accuracy between the position of the nipple and the top side of the pallet is not required.

Variant C:

Ideal fastening variant for clamping for manufacturing with reversing. The highest accuracy is ensured because the nipple is fastened in the same mounting bore.

Variant D, E:

These fastening variants are to be preferred. The precision bore for the nipple and all necessary positioning bores on the pallet can be manufactured in one work step. As a result the accuracy between the positions is very high.

Special nipple fastenings are required for these variants (3.4).



Nipple fastening D

**Characteristics:**

Makes it possible to fasten the nipple with one clamping action. As a result the highest accuracy is achieved.

Application:

Machine pallets, machine vices, chucks, jigs, direct workpiece clamping.

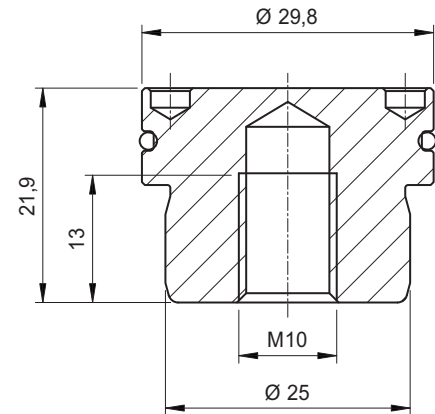
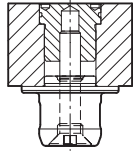

Z 804 267

Order no.	Weight	Data sheet
804 267	0.09 kg	D029

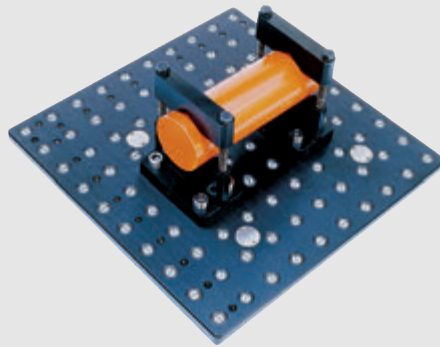
**Application example**

Nipple fastening D

Nipple fastening E

**Characteristics:**

Makes it possible to fasten the nipple with one clamping action. As a result the highest accuracy is achieved.

Application:

Machine pallets, machine vices, chucks, jigs, direct workpiece clamping.

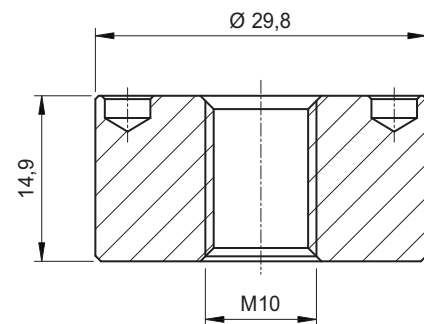
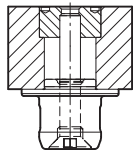

Z 804 266

Order no.	Weight	Data sheet
804 266	0.05 kg	D029





Application example

Nipple fastening A



Application example

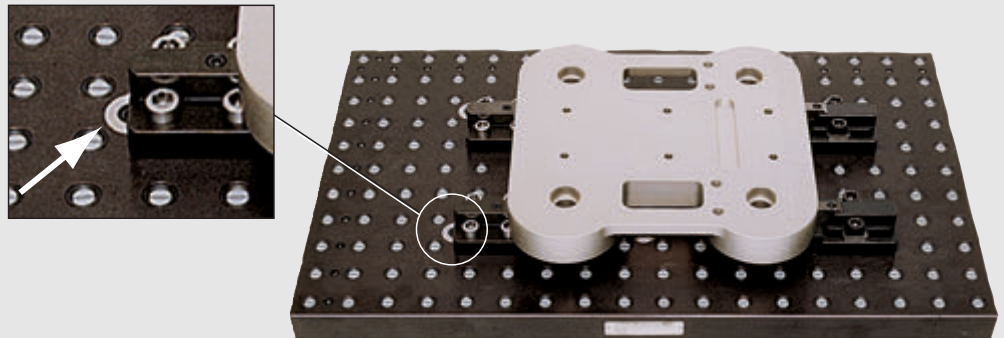

Nipple fastening E



Countersunk head screw



Characteristics:

Countersunk head screw M10.

Application:

Retractable nipple fastening (for fastening variant A).

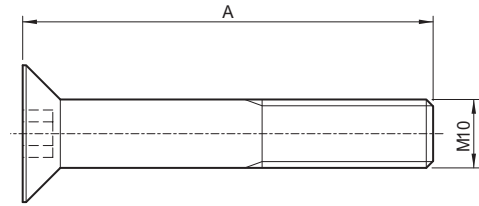

Z 931 916

Order no.	Dimension	Application material	Size A	Strength class	Data sheet
931 506	M10 x 50 - DIN 7991	Steel	50 mm	10.9	D029
931 916	M10 x 60 - DIN 7991	Aluminium	60 mm	10.9	D029



Application example

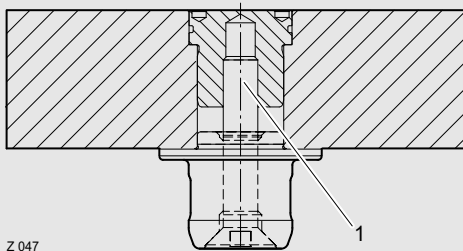

1) Countersunk head screw

Z 047

Bearing plate Ø 138



Characteristics:

Bearing plate made of hardened steel.

High resistance to wear with unhardened machine pallet surfaces.

Application:

Bearing plate for SPEEDY classic 2 TWISTER or SPEEDY classic 2 TORNADO. For the usage of unhardened machine pallet surfaces.

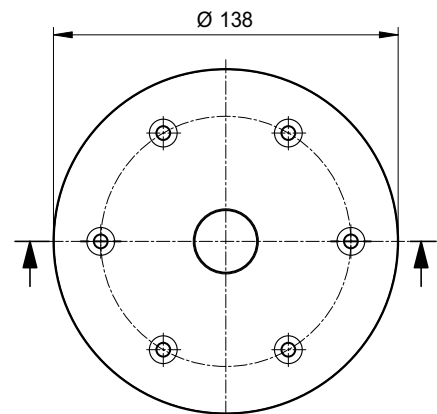
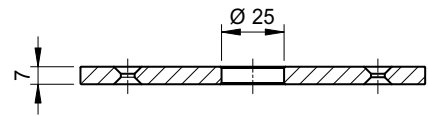

Z 804 281

Order no.	Surface	Weight	Data sheet
804 281	Ground on both sides	0.78 kg	D033
804 281-R	Unfinished on one side for subsequent grinding – in assembled state	0.78 kg	D033

Fastening screws not included with the items supplied.



Spacer washer for TWISTER

- with O-ring



Characteristics:

Very precise mount control (down to 0.01 mm) possible, as due to the sealing of the centre bore, air can only escape at the 4 raised supports.

Application:

Spacer washer for sealing the centre bore and for equalising the height for SPEEDY classic TWISTER.

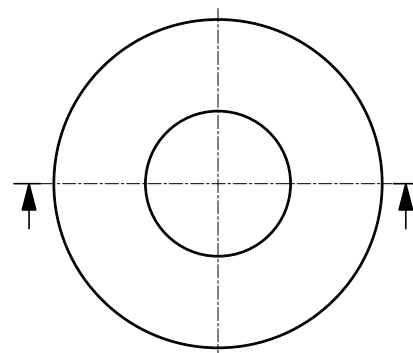
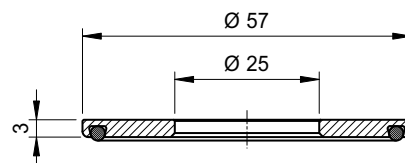

Z 804 280

Order no.	Weight	Data sheet
804 280	0.02 kg	D033



Sectional view

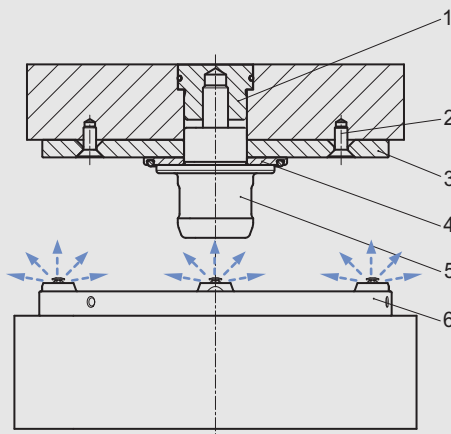

- 1) Nipple fastening
- 2) Countersunk screw
DIN 7991
- 3) Hardened bearing plate
- 4) Spacer washer
- 5) Retractable nipple
- 6) SPEEDY Twister

Practical example

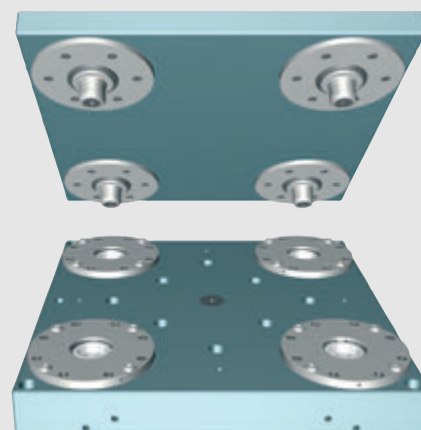

SPEEDY classic 2 TWISTER fast closing clamps, fitted in plate

The spacer washer (4) is imperative for each SPEEDY classic 2 TWISTER and must be fitted to each retractable nipple!



Pressure booster

4

The pressure boosters from STARK convert air pressure into hydraulic pressure and can be used from 30 to 180 bar.

With the "third hand" function (DHF) the workpiece or pallet is held in the position engaged after positioning.

Workpiece and pallet are thus secured against falling out and no longer need to be held by the operators. The clamping process is even quicker and safer.

- * Engage, let go and clamp!
- * Couple and simply release!





The "third hand" function – the option for process safety:

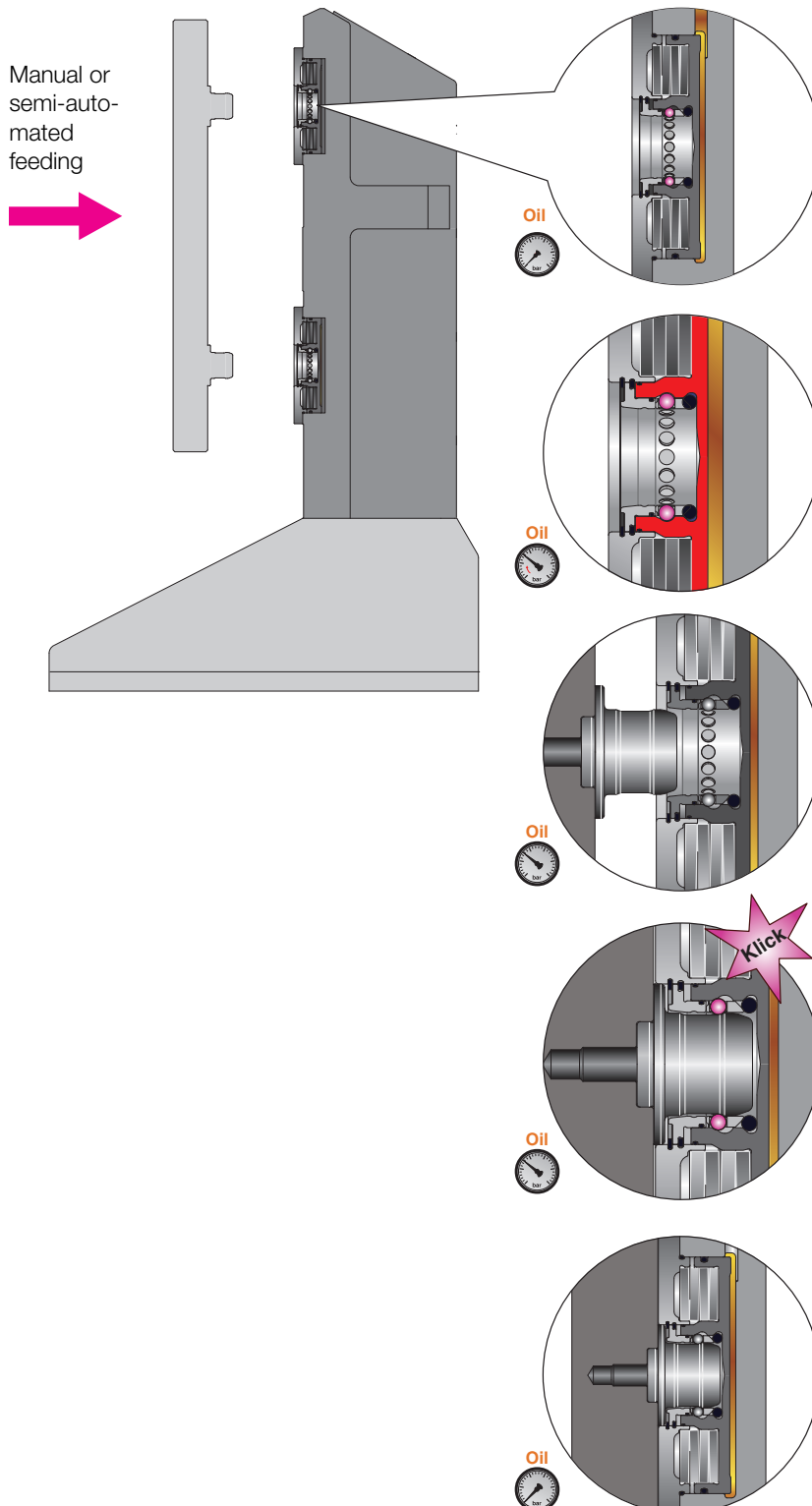

Manual or semi-automated feeding



"Third hand" function, DHF

Explanation based on a SPEEDY classic 2

Retention function

The retention pressure is applied to the SPEEDY and the SPEEDY is ready for securely engaging the pallet.

Feed

The pallet is moved by hand or by crane.

Engage

The retractable nipples are inserted, engaged and are then mechanically secured.

You can let go of the pallet.

Position and clamp

The SPEEDY is de-pressurised. The pallet is now positioned, pulled in and securely clamped using the plate springs.

Function animation also at www.stark-inc.com





RECORD



Characteristics:

The pressure booster RECORD converts air pressure to the necessary hydraulic system pressure for the operation of the SPEEDYs.

Application:

Operation of 7 SPEEDY fast closing clamps up to max. 40 bar (SPEEDY classic 2).

Can also be used for other sizes (adjustment using pressure regulator).

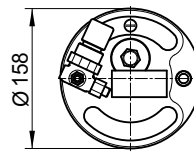
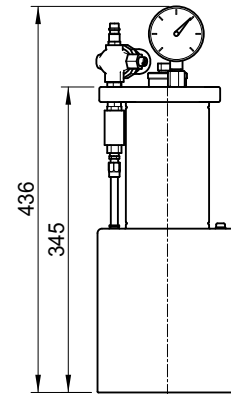

Z 804 411

Order no.	Releases approx. [pcs.]	System pressure	Air pressure	Oil volume	Weight
804 411	7 SPEEDY	40 bar	6 bar	0.31 l	8.80 kg

Pressure booster can be expanded to DHF using article 804 427.

Hydraulic connection via hydraulic coupler 804 371, hydraulic hose not included with the items supplied.

BOOSTER

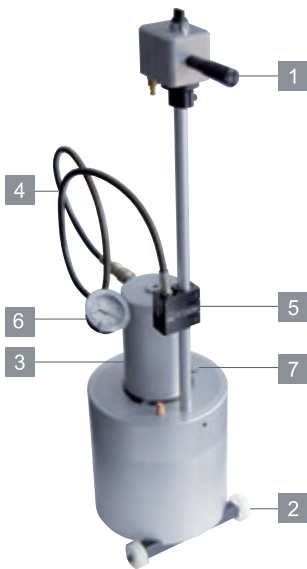

Characteristics:

The booster is used for releasing single-acting clamping systems. It converts compressed air into hydraulic pressure and is suitable for ranges from 30 to 80 bar.

Application:

- 1 Handle for safe transport
- 2 Two robust rollers and one foot for secure positioning (can be removed easily for stationary applications)
- 3 Pressure 40 bar with 1 litre oil capacity for more than 20 SPEEDY classic 2 (also available with 80 bar pressure)
- 4 Hose available in various lengths also with self-sealing quick-release coupling
- 5 Holder for coupling for safe transport and for storage
- 6 Hydraulic pressure gauge with maximum pressure marking
- 7 Dipstick

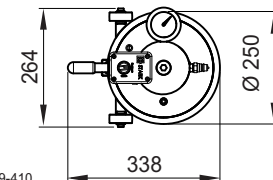
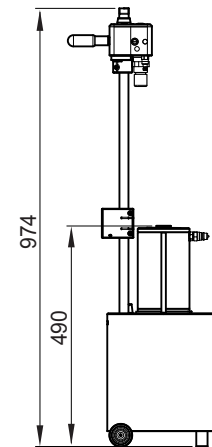

Z 099-410

Order no.	Releases approx. [pcs.]	System pressure	Air pressure	Oil volume	Weight
804 432	24 SPEEDY	40 bar	6 bar	1 l	27,30 kg
804 433	11 SPEEDY	80 bar	6 bar	0.5 l	27,30 kg

Pressure booster can be expanded to DHF using article 804 427.

Hydraulic connection via hydraulic coupler 804 371, hydraulic hose not included with the items supplied.



Hydraulic hose with couplings



Characteristics:

Hydraulic hose with hydraulic coupler on both ends.

Application:

Is used for the connection between pressure booster and fast closing clamp plate or SPEEDY classic 2 Surface Mount.

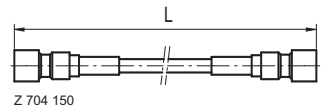

Order no.	Self-sealing couplings	L	Max. pressure	Weight
704 150	No (952 044)	1.5 m	300 bar	0.60 kg
704 151	Yes (952 177)	1.5 m	300 bar	0.60 kg
704 152	No (952 044)	3.0 m	300 bar	0.60 kg
704 153	Yes (952 177)	3.0 m	300 bar	0.60 kg

Pedal control



Characteristics:

Pedal control for operating the pressure booster.

Application:

Operation of the pressure booster using a foot control.

The pressure booster does not need to be in the immediate vicinity.

Both hands are free for loading or for removing the workpieces to be machined.

Order no.	Description	Weight
804 419	Pedal control for pressure booster (incl. pneumatic hose and male connections)	1.50 kg



Application example





DHF pedal control (third hand function)

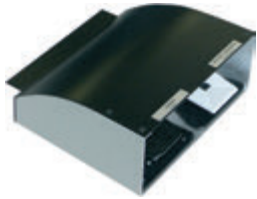

Characteristics:

Due to the special control of the pressure (operation) to the fast closing clamps, the workpiece, the pallet or the jig can be straightforwardly engaged. Feed, engage and clamp.

Application:

On a vertical clamping system or in case of feed by robots or handling systems.

Order no.	Description	Weight
804 427	DHF pedal control for pressure boosters (incl. pneumatic hose and male connections)	4.00 kg

Hydraulic pump set



Characteristics:

Hydraulic pump set optionally with DHF function and sampling of the clamping check.

With integrated hydraulic and electrical control via remote control with 7m cable (with Harting connector).

Function triggered using control panel with three illuminated pushbuttons.

Supplied with hydraulic oil HLP32 and electrical connection with 10m long cable and 400 V connector.

Technical data:

Q = 3.2 l/min

V = 11 l

U = 400 V 50 Hz ~3PE

p = 45/15 bar

P = 0.55 kW

Valve and control voltage: 24 VDC

Medium: Hydraulic oil HLP32

DIN 51519/51524 Part 2

Connections: G 1/4

Application:

Particularly suitable for small to medium-sized clamping and mounting devices with single action cylinders that operate primarily with intermittent duty (pressure build-up and pressure retention).

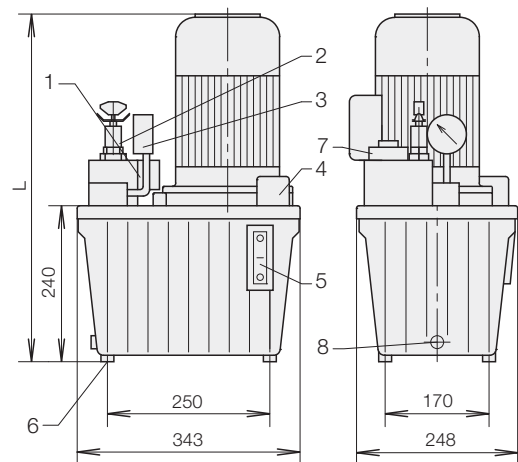

Z 8223 310

- 1) Filter check
- 2) Pressure limiting valve
- 3) Pressure gauge
- 4) Filler and breather filter
- 5) Oil level gauge
- 6) 4 fastening holes M8 x 8 deep
- 7) High pressure filter
- 8) Oil drain plug G 3/8

Order no.	Description	Weight
804 443	Hydraulic pump set with sampling of the clamping check	27 kg
804 444	Hydraulic pump set with sampling of the clamping check and DHF function	27 kg
804 445	Hydraulic pump set with DHF function	27 kg

For more detailed information, refer to RÖMHELD data sheet D8.021.

Other pump units available on request.





Application example



Easy, quick changing of a jig with SPEEDY classic 2, couple, release and lift off. Due to the contour of the retractable nipples, it is also possible to remove asymmetrical jigs at an angle.



Plates, angles, mounting towers

5

STARK develops and manufactures mounting towers to your requirements or drawings.

Your advantages:

- Direct application of your CAD data
- In-house Engineering department
- Air-conditioned measuring room with the latest instruments
- QA report on delivery for your quality management
- One contact for complete order processing

*Mounting towers and fast
closing clamp plates from
in-house manufacture ...
everything from a single source!*





Flexible clamping solutions for the latest manufacturing systems:



SPEEDY classic 2 fast closing clamps, fitted in round plate.



SPEEDY classic 2 fast closing clamps, fitted in each side of the mounting tower.



SPEEDY classic 2 fast closing clamps, fitted in rectangular plate.



SPEEDY classic 2 fast closing clamps, fitted in round plate on setup station.

STARK manufactures all applications in-house. Customer-specific solutions are optimally adapted to your requirements.

Consultation, planning, design, production, mounting, service – everything from a single source!



Fast closing clamp plate



Characteristics:

Fast closing clamp plate with SPEEDY classic 2 STANDARD.

Application:

On 3/4/5 axis machines for all common machining tasks such as milling, turning, grinding, eroding.

Detailed information to suit your machine on request.

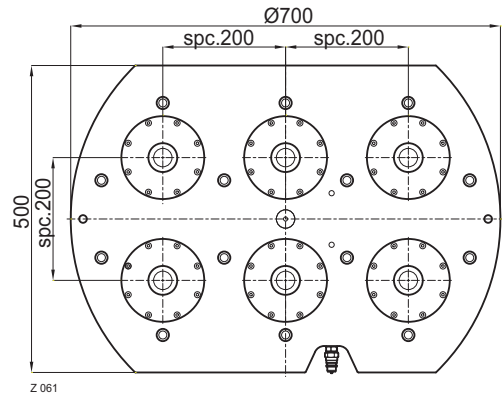

Order no.	Retention force	Insertion force	Hydr. pressure to release	Spacing	Weight	Machine type
105 100	38,000 N	20,000 N	35-40 bar	200 ± 0.01	86 kg	DMU 70

Fast closing clamp face plate



Characteristics:

Fast closing clamp face plate incl. clamping check, connecting shaft and rotary joint with SPEEDY classic 2 STANDARD.

Application:

On lathes and grinding machines.

Detailed information to suit your machine on request.

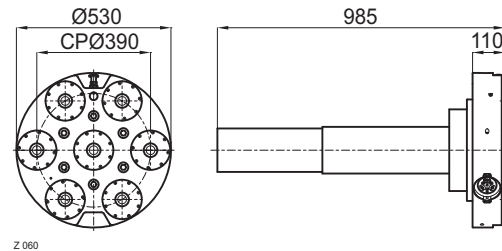

Order no.	Retention force	Insertion force	Hydr. pressure to release	Weight	Machine type
105 110	38,000 N	20,000 N	35-40 bar	273 kg	WFL



Detail



The fast closing clamp face plate is equipped with a multifunctional coupling system





Angle



Characteristics:

Angle with SPEEDY classic 2 STANDARD.

Application:

Can be used on machine tools for all common machining tasks.

IMPORTANT: pressure booster with DHF function required (see section 4).

Other angles available on request.

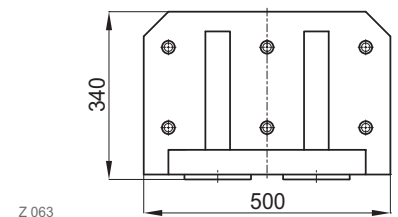
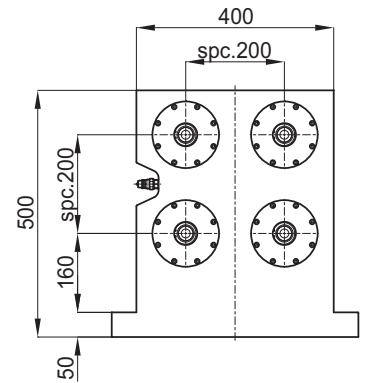

Order no.	Retention force	Insertion force	Hydr. pressure to release	Spacing	Weight
105 120	38,000 N	20,000 N	35-40 bar	200 ± 0.01	160 kg

Double angle

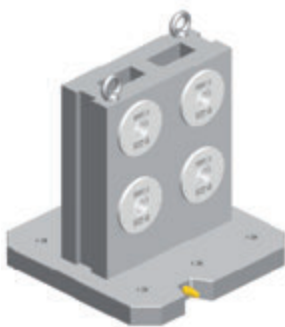

Characteristics:

Double angle with SPEEDY classic 2 STANDARD.

Application:

Can be used on machine tools for all common machining tasks.

Other double angles available on request.

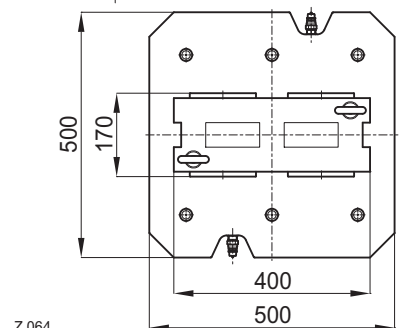
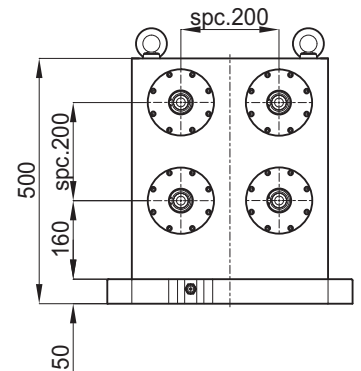

Order no.	Retention force	Insertion force	Hydr. pressure to release	Spacing	Weight
105 130	38,000 N	20,000 N	35-40 bar	200 ± 0.01	260 kg

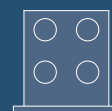



Mounting tower

- With valve system



Characteristics:

Mounting tower with valve system with SPEEDY classic 2 with integrated media ducts.

The supply of energy is coupled automatically during positioning and clamping.

Actuation by manually operated valve on the mounting tower (each side can be controlled separately).

Application:

Can be used on machine tools for all common machining tasks.

For usage of pallets with hydraulic actuation, pneumatic sampling etc.

Other mounting towers with valve system available on request.

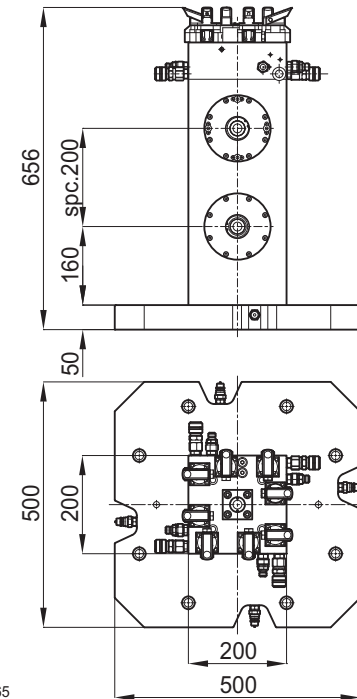

Z 065

Order no.	Retention force	Insertion force	Hydr. pressure to release	Spacing	Weight
105 140	38,000 N	20,000 N	35-40 bar	200 ± 0.01	238 kg

Mounting tower



Characteristics:

Mounting tower with valve system with SPEEDY classic 2 with integrated media ducts.

The supply of energy is coupled automatically during positioning and clamping.

Application:

Can be used on machine tools for all common machining tasks.

Other mounting towers available on request.

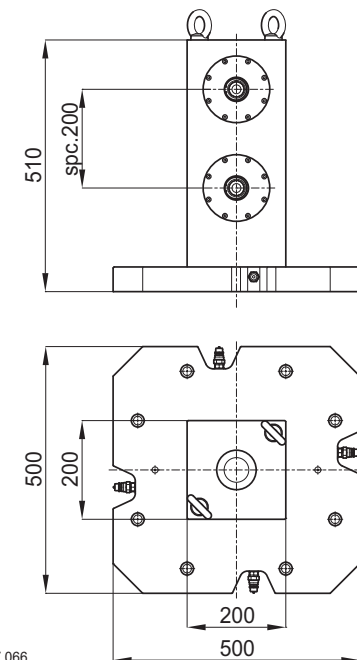

Z 066

Order no.	Retention force	Insertion force	Hydr. pressure to release	Spacing	Weight
105 150	38,000 N	20,000 N	35-40 bar	200 ± 0.01	215 kg



Vice pallet



Characteristics:

Pallet with machine vice for mounting on mounting towers or fast closing clamp plates, two media ducts on the underside.

Application:

Can be used on machine tools for all common machining tasks.

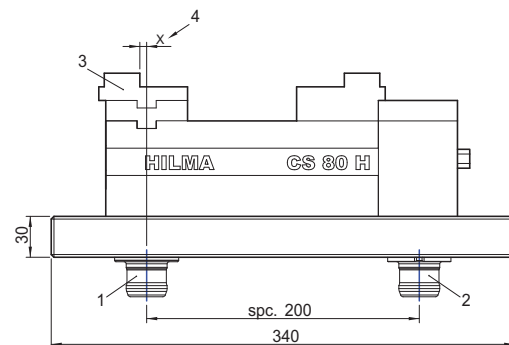

Z 050

- 1) Nipple with zero point
- 2) Nipple with equaliser
- 3) The distance X between the nipple with zero point and the fixed jaws should always be kept the same if several identical vices are fitted! (Standard tolerance at STARK ± 0.01)

Order no.	Spacing	Vice HILMA CS 80 H	Weight
105 080	200 \pm 0.01	with	22 kg
105 090	200 \pm 0.01	without	12 kg



Application example

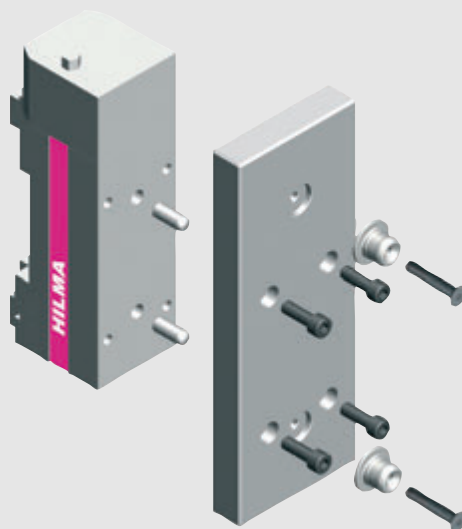

On the usage of media ducts the machine vice can be operated directly.

Extension of the machine pallet to jig with integrated HILMA machine vice

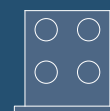

Media ducts (MD)

6

Media ducts are used to carry media, e.g. oil, air, water etc. through the zero point clamping system SPEEDY classic.

They allow, e.g. clamping devices fitted to the machine pallets to be supplied with power (hydraulic oil, compressed air).

Media ducts comprise two components – one for installation in SPEEDY and one for installation in the pallet that is automatically coupled when the retractable nipples are clamped.

Zero point clamping and media duct integrated into one system!



Complex zero point clamping solutions using media duct:

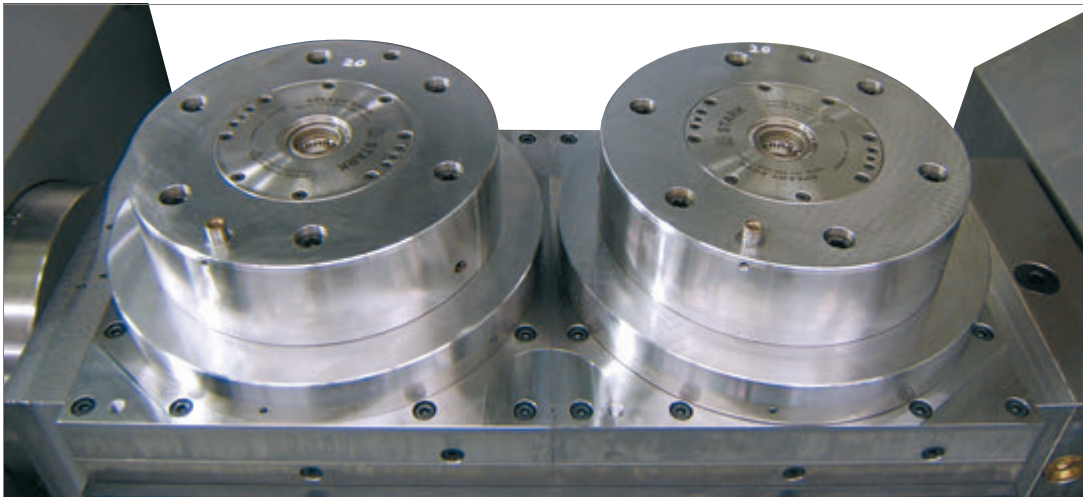

SPEEDY classic 2 with two integrated media ducts, fitted to swivelling yoke.



SPEEDY classic 2 with one integrated media duct, e. g. for actuating a machine vice or a system check.



SPEEDY classic 2 with 3 media ducts, e. g. for operating double-action swing clamps and supporting elements.



Information on the media duct NW 4

Advantages

- Media ducts can be integrated directly in the SPEEDY zero point clamping system.
- Up to 4 media ducts per SPEEDY are possible.
- The coupling travel is adjusted to the travel of the SPEEDYs.

Technical data

Min. coupling force	Operating pressure	Flow rate
250 N	Max. 200 bar	28 l/min with static pressure of 90 bar on HLP 46

Formulas for calculations

Insertion force SPEEDY classic 2 = 20,000 N

Coupling force F [N] = (250 + 7.1 x p [bar]) x n

(n = number of pipes pressurised to the same pressure in coupled state)

- Unpressurised pipes are subject to 250 N spring force.
- The sum of the axial forces on the media ducts acts against the insertion force on the SPEEDYs.
- The actuating force and the coupling force to be absorbed must not exceed the insertion force on the zero point clamping system!

Diagram for determining the coupling force per media duct NW 4

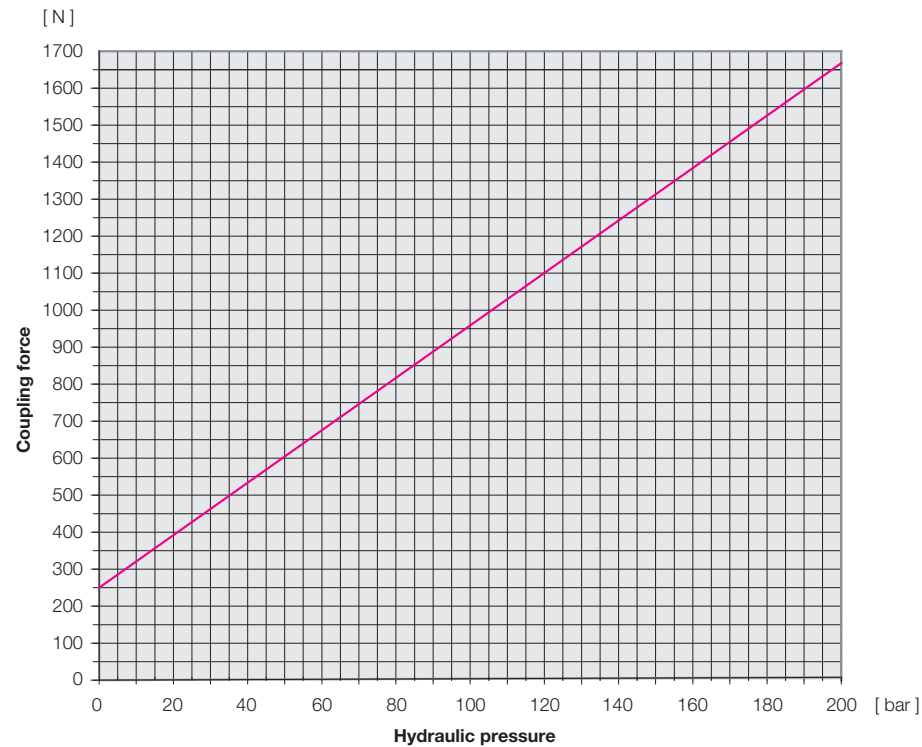

Important notes for the correct usage of the media ducts:

- The media ducts are only allowed to be coupled when unpressurised.
- Machine pallets with media ducts fitted are not allowed to be pressurised when uncoupled.
- Concentric pre-positioning of \varnothing 0.2 mm is necessary.
- Both media duct components are closed when uncoupled.

Our consultants will be pleased to advise you on the correct usage of media ducts.



Media duct NW 4 coupling mechanism

- SPEEDY side
- With mounting flange



Characteristics:

Media duct for the supply of hydraulic oil and air, other media on request.

The media duct is coupled by the drawing in stroke of the fast closing clamps and is self-sealing when uncoupled.

Together with the SPEEDY classic fast closing clamps, the necessary positioning is provided by the fast closing clamps.

Application:

For direct installation in fast closing clamps, as well as single and multiple couplings with and without blow-out ducts.

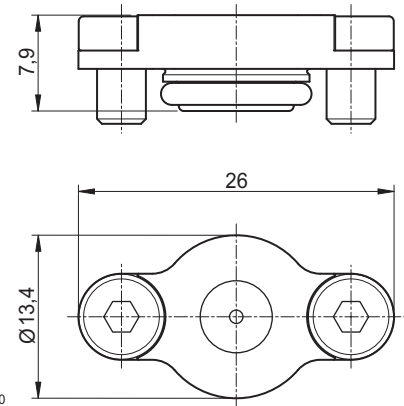

Z 704 200

Order no.	Max. coupling force	Weight	Data sheet
704 200	See diagram at the start of this section	0.02 kg	D023

Fastening screws included with the items supplied.

Media duct NW 4 coupling nipple

- Pallet side
- With mounting flange



Characteristics:

Media duct for the supply of hydraulic oil and air, other media on request.

The media duct is coupled by the drawing in stroke of the fast closing clamps and is self-sealing when uncoupled.

Application:

For direct installation in machine pallets, as well as single and multiple couplings with and without blow-out ducts.

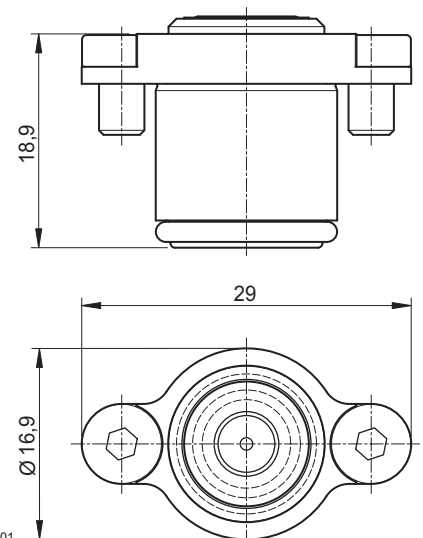

Z 704 201

Order no.	Max. coupling force	Weight	Data sheet
704 201	See diagram at the start of this section	0.03 kg	D025

Fastening screws included with the items supplied.



Application example

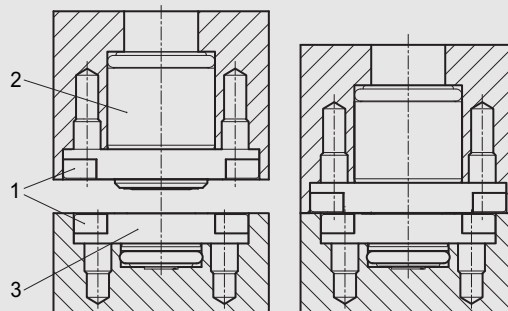

- 1) Fastening screws
- 2) Media duct pallet side
- 3) Media duct SPEEDY side



Media duct NW 4 coupling nipple

- Pallet side



Characteristics:

Media duct for the supply of hydraulic oil and air, other media on request.

The media duct is coupled by the drawing in stroke of the fast closing clamps and is self-sealing when uncoupled.

Application:

For two-piece installation in machine pallets, as well as single and multiple couplings with and without blow-out ducts, e. g. combined with hardened bearing plate.

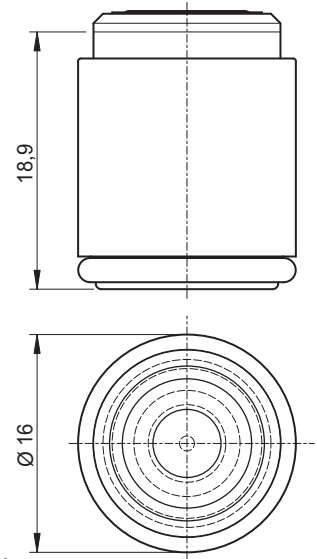

Z 704 203

Order no.	Max. coupling force	Weight	Data sheet
704 203	See diagram on page 6.2	0.02 kg	D083



Application example

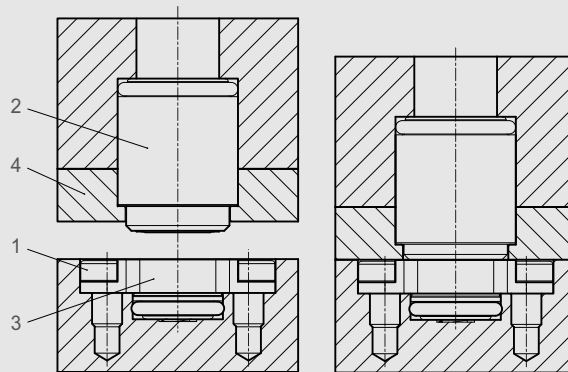

- 1) Fastening screws
- 2) Media duct pallet side
- 3) Media duct SPEEDY side
- 4) Bearing plate



Multiple coupling NW4 coupling mechanism

- SPEEDY side

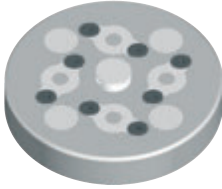

Characteristics:

Media duct with one or more control circuits.
Integrated blow-out ducts.

Application:

Operation of jigs or hydraulic vices on machine pallets.
Particularly suitable for automated loading due to integrated blow-out ducts.
Upgrading existing zero point clamping system with media ducts.

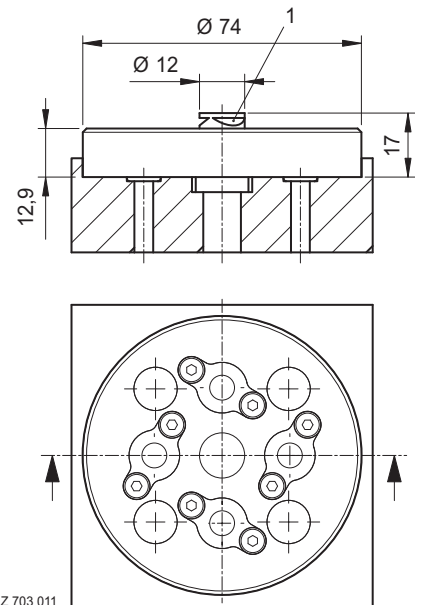

Order no.	Pos. and number of the media ducts (see fig. on page 6.7)	Weight	Data sheet
703 009	1	0.50 kg	D042
703 010	2	0.50 kg	D042
703 012	3	0.50 kg	D042
703 011	4	0.50 kg	D042

Fastening screws and screw covers included in the items supplied.



Characteristics:

Media duct with six control circuits.
Integrated blow-out ducts.

Application:

Operation of jigs or hydraulic vices on machine pallets.
Particularly suitable for automated loading due to integrated blow-out ducts.
Upgrading existing zero point clamping system with media ducts.

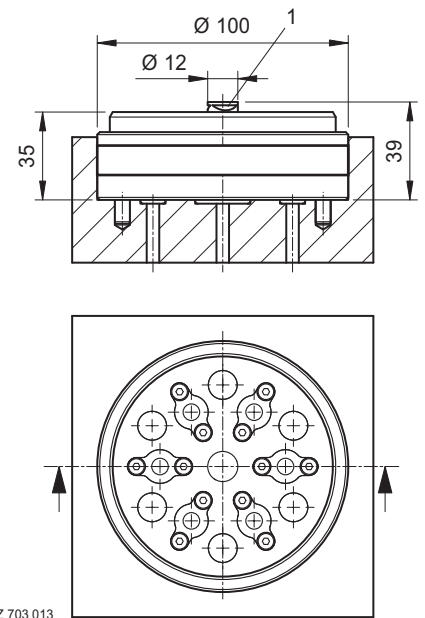

Order no.	Pos. and number of the media ducts (see fig. on page 6.7)	Weight	Data sheet
703 013	6	2.00 kg	D059
703 022	5	2.00 kg	D059

Fastening screws and screw covers included in the items supplied.

Multiple coupling NW4 coupling nipple

• Pallet side



Characteristics:

Media duct with 1-4 control circuits.
Integrated blow-out ducts.

Application:

Operation of jigs or hydraulic vices on machine pallets.
Particularly suitable for automated loading due to integrated blow-out ducts.
Upgrading existing zero point clamping system with media ducts.

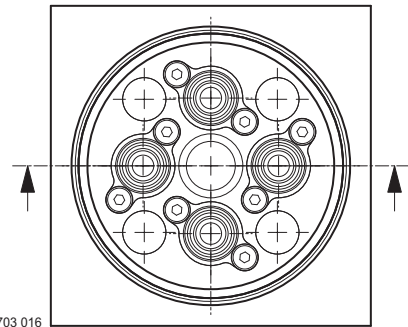
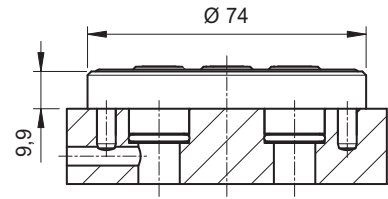

Z 703 016

Order no.	Pos. and number of the media ducts (see figure on page 6.7)	Weight	Data sheet
703 014	1	0.50 kg	D040
703 015	2	0.50 kg	D040
703 017	3	0.50 kg	D040
703 016	4	0.50 kg	D040

Fastening screws and screw covers included in the items supplied.



Characteristics:

Media duct with six control circuits.
Integrated blow-out ducts.

Application:

Operation of jigs or hydraulic vices on machine pallets.
Particularly suitable for automated loading due to integrated blow-out ducts.
Upgrading existing zero point clamping system with media ducts.

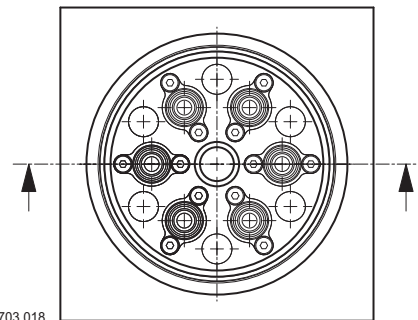
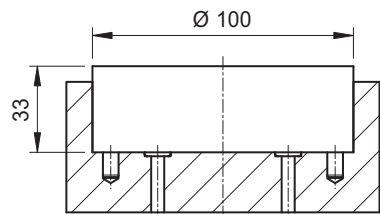

Z 703 018

Order no.	Pos. and number of the media ducts	Weight	Data sheet
703 018	6	1.50 kg	D059
703 023	5	1.50 kg	D059

Fastening screws and screw covers included in the items supplied.





Application example

1x coupling

2x coupling

3x coupling

4x coupling

6x coupling

- 1) Compressed air
- 2) Feed 1
- 3) Return 1
- 4) Feed 2
- 5) Return 2
- 6) Feed 3
- 7) Return 3

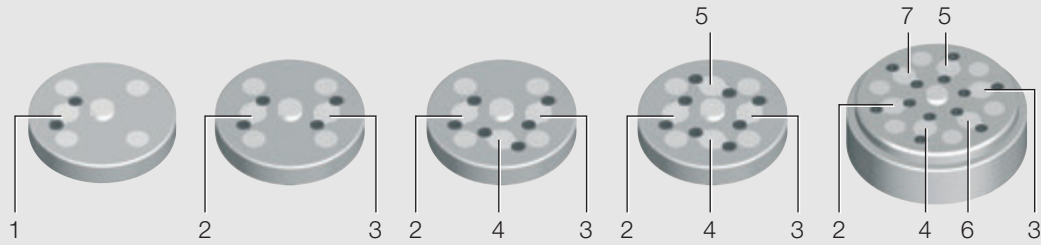

Note:

Depending on the number of media ducts, the insertion force of the SPEEDYs will change (see illustration on page 6.2).

Media duct NW 4 blanking plug



Characteristics:

Blanking plug for media ducts.

Application:

For sealing media ducts that are not required.

Matches 704 200 on the Speedy side.

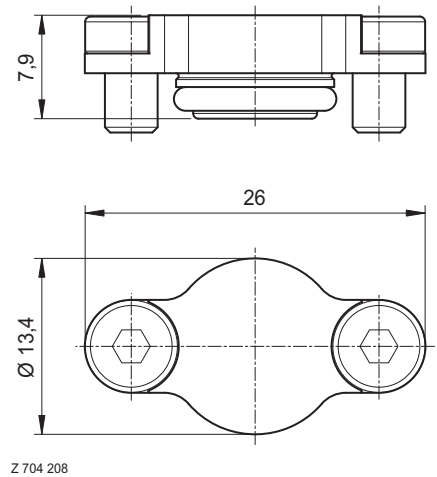

Order no.	Weight	Data sheet
704 208	0.01 kg	D023

Fastening screws included with the items supplied.



Media duct pliers



Characteristics:

Due to the matched contour of the media duct pliers, the media duct is not damaged during removal.

Application:

Pliers for removing media ducts.

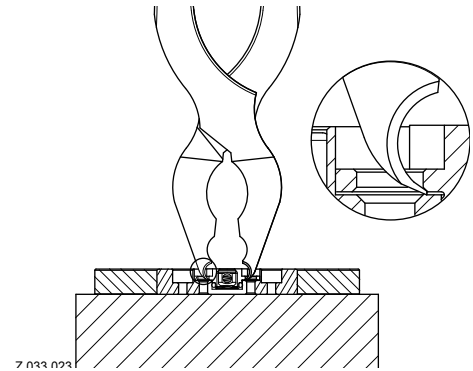

Order no.

504 015

Weight

0.18 kg



Practical example

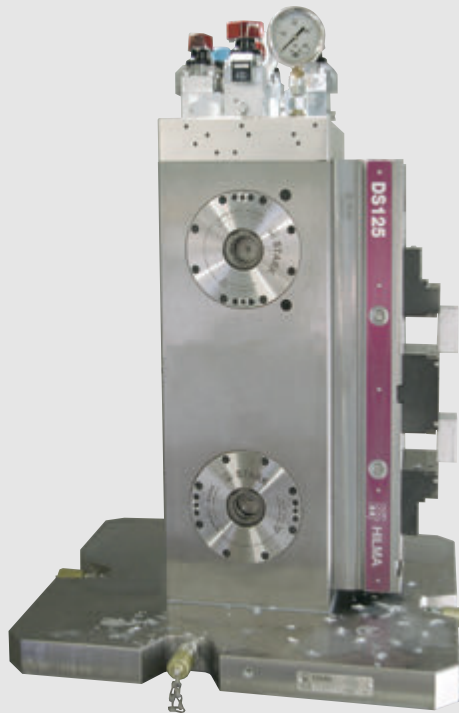

SPEEDY classic 2 fast closing clamps with media ducts fitted to each side of the mounting tower. Machine vises are operated by the control valves fitted at the top.



Clamp control valve

- Mechanical



Characteristics:

Control valve for checking for secure clamping.

Application:

The clamping check must be used on all rotary machines!

Particularly important for vertical changing processes and on lathes.

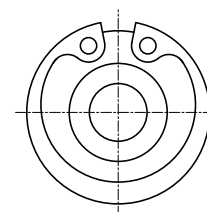
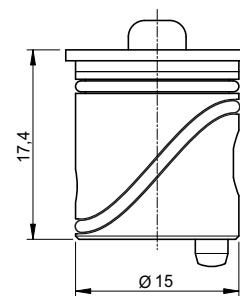

Z 704 210

Order no.	Max. pressure	Weight	Data sheet
704 210	10 bar	0.01 kg	D024



Hydraulic schematic

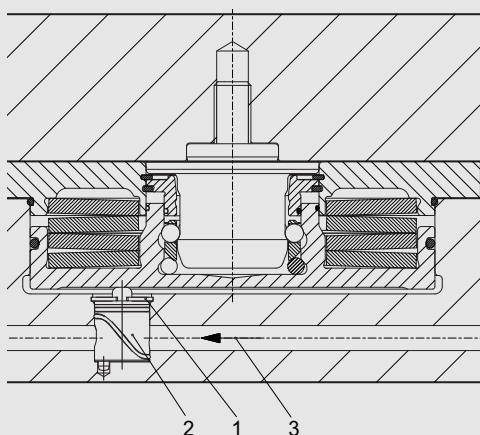

- 1) Locking ring
- 2) Clamp control valve
- 3) Flow direction
- 4) SPEEDY
- 5) Pressure switch for clamping signal
- 6) Hydraulic valve for clamping check
- 7) Hydraulic valve for releasing the SPEEDY
- 8) Pressure limiting valve, 40 bar (80 bar)
- 9) Pressure limiting valve, 8 bar
- 10) Oil supply from machine
- 11) Non-return valve (bypass)

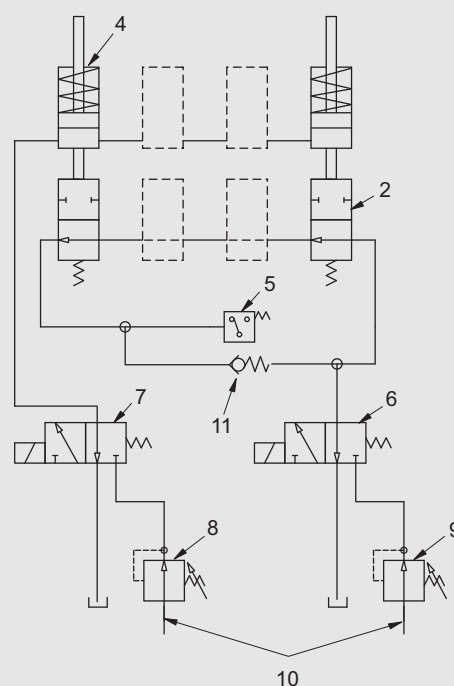

Z 704 210-2

This hydraulic schematic is only an example and explains the principle of operation.



Explanation of function

The correct and safe clamping of the fast closing clamp is checked on each clamping action by using the mechanical clamp control valve (item 2). If a retractable nipple is not clamped or is not clamped correctly, the piston moves past the normal position and with the clamp control valve inhibits the flow in the hydraulic pipe (item 3). This signal can be easily integrated into the control system, e.g. hydraulic unit, external evaluation of machine control system.

On plates or in towers all fast closing clamps are polled in series – as a result the exact clamping of all fast closing clamps can be checked at any time.



SPEEDY accessories

7

For maintenance, transport and installation of your SPEEDY's we supply the right accessories.

They ensure optimal care and a long service life.

*SPEEDY special tools for maintenance,
transport and installation*



Shut-off valve

- Flush Mount



Characteristics:

Shut-off valve for installation in the fast closing clamp plates.

Application:

Shutting off individual clamping circuits. Opening and closing by 90° rotation using hex wrench.

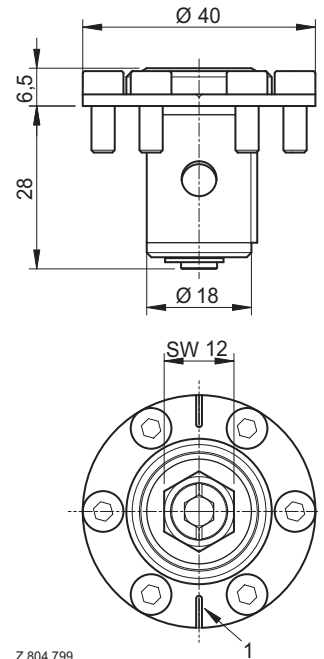

Z 804 799

1) Marking for flow

Order no.	Description	Max. pressure	Weight
804 799	Shut-off valve incl. spanner for installation	150 bar	0.30 kg



Procedure for installation

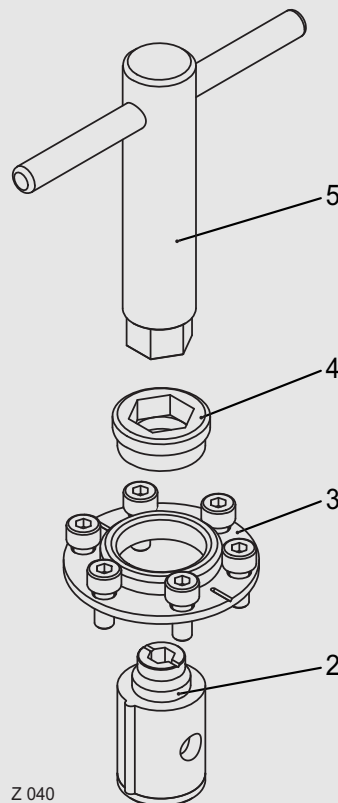

Slide sealing sleeve (2) and valve pin into the bore. Fit threaded flange (3) using the 6 pcs. M4 screws. Screw adjusting screw (4) into the threaded flange. Then tighten the adjusting screw using the spanner for installation (5).

Note: Subsequent sealing possible by tightening the adjusting screw (4).





Torque wrench



Characteristics:

Adjustable torque wrench.

Application:

Fitting and removing retractable nipples. Note torque data in the related operating instructions!

Order no.	Adjustment range	Accessory	Weight
804 255	5 - 50 Nm	3/8" drive for hex socket head AF 4, AF 5, AF 6	0.60 kg
804 256	20 - 100 Nm	1/2" drive for hex socket head AF 10, socket 1/2" AF 22	

When fitting nipples, note torques as per technical data.

Sealing plug

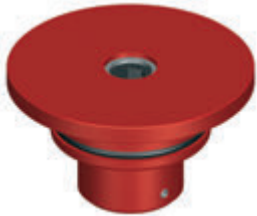

Characteristics:

Sealing plug with O-ring that prevents the entry of dirt (e.g. coolant).

Application:

Protection for unused SPEEDY fast closing clamps.

Sealing plug (2) is pressed out of the SPEEDY by turning the screw (1) clockwise.

Return spacer (3) to original position prior to inserting again.

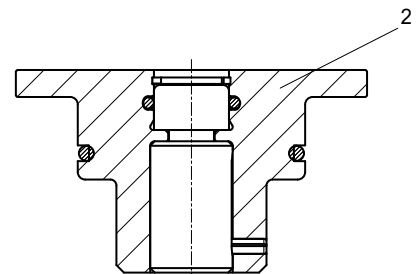
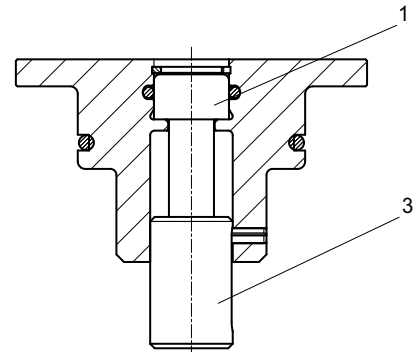

Z 704 099

- 1) Screw
- 2) Sealing plug
- 3) Spacer

Order no.	Description	Weight
704 099	Sealing plug for SPEEDY classic 2	0.04 kg

Covering with longer pallets, workpieces or jigs is possible with the recessed sealing plug.





Application example

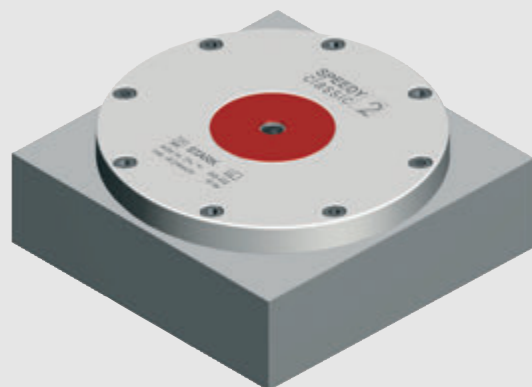

Transport protection



Characteristics:

Plastic protective cap.

Application:

Protection against damage to the retractable nipple and pallet surface during transport or stacked storage.

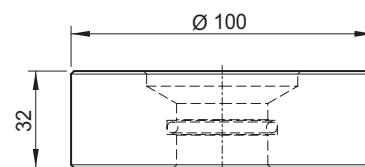

Z 704 133

Order no.	Description	Weight
704 133	Transport protection for SPEEDY classic 2 retractable nipple	0.30 kg

For SPEEDY classic 2 with media ducts a special version of the transport protection is supplied – please state in the order.



Application example

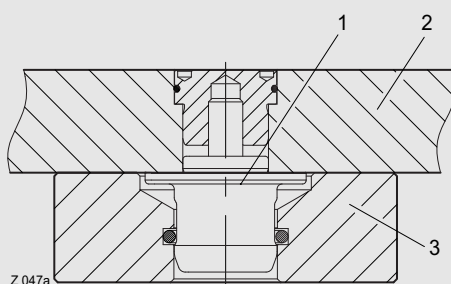

- 1) Retractable nipple
- 2) Pallet
- 3) Transport protection



Service-set O-rings

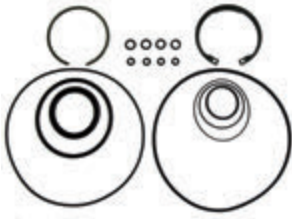

Characteristics:

Service-set comprising all O-rings and the locking ring.

Application:

Maintenance of SPEEDY classic 2 fast closing clamps.



Attention:

The fast closing clamp is always under spring pressure!

Only an authorised service engineer is allowed to undertake installation work on the fast closing clamps. All necessary safety measures are to be taken without exception during all work!

Order no.	Description	Weight
804 193	Service set for SPEEDY classic 2	0.01 kg

Service set cup springs



Characteristics:

Service set comprising cup springs for SPEEDY classic 2.

Application:

Maintenance of SPEEDY classic 2 fast closing clamps.



Attention:

The fast closing clamp is always under spring pressure!

Only an authorised service engineer is allowed to undertake installation work on the fast closing clamps. All necessary safety measures are to be taken without exception during all work!

Order no.	Description
804 953	Cup spring pack for SPEEDY classic 2 (20.000 N) 4 pieces

STARK recommends regularly checking the insertion force using the mechanical insertion force tester (order no. 504 002).

Circlip pliers



Characteristics:

180 mm internal, straight version.

Order no.	Description	Weight
504 006	Circlip pliers	0.20 kg



Application example

Removal of the locking ring for easy dismantling

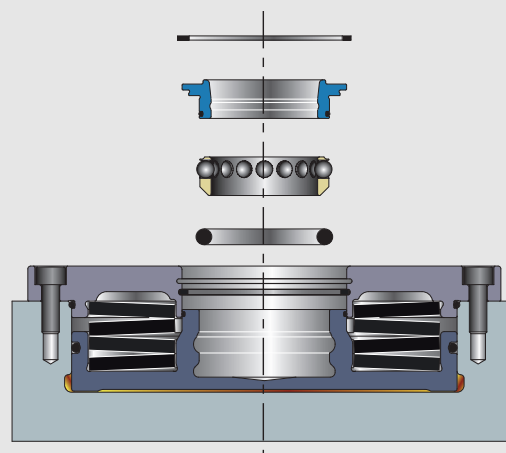

Mechanical insertion force tester



Characteristics:

The insertion force on the SPEEDY fast closing clamps is reliably checked with the aid of the SPEEDY insertion force tester. Fatigued spring packs can cause the insertion force to change as a function of the actuation cycles and wear, the insertion force stated is then no longer reached and the machining forces are no longer fully absorbed by the SPEEDY zero point clamping system. STARK recommends an annual preventative check on the fast closing clamps (note operating instructions or table in the introduction, i.8).

Application:

Installers, fitters and operators who assemble, fit, service and operate the SPEEDY zero point clamping system. They should be familiar with the use of hydraulic equipment. Attention, only trained personnel are allowed to perform all service and maintenance work.

Order no.	Description	Weight
504 002	Mechanical insertion force tester SPEEDY classic 2	2.70 kg
	Bearing ring	0.90 kg
	Adapter - retractable nipple SPEEDY classic 2	0.80 kg
	Spacer washer, for SPEEDY classic 2 Twister	0.02 kg
	SET weight:	5.70 kg



The system accuracy depends not only on the geometry of the joint, the insertion force of the zero point clamping systems also has a significant impact on a positive, stable joint.

For safety reasons it is recommended to regularly check the insertion force of the SPEEDY zero point clamping system.

For this purpose, STARK offers a fully mechanical insertion force tester. Its principle of operation is based on a linear change in the length of components that is proportional to force. The length change is converted into a force and indicated on an analogue dial gauge.

The mechanical insertion force tester is characterised by its accuracy (measurement precision $\pm 3\%$) and robustness. Low cost and reliable, without any electronics. We supply the mechanical insertion force tester calibrated, with inspection stamp and measuring instructions in a high quality plastic box.

STARK provides training courses for training your operators and service personnel. Training courses are held on site or at Stark Spannsysteme GmbH.

Please ask for information, we would be pleased to advise you.

Supplied in plastic case:

(L390 x W280 x H110)



Insertion force tester (1) with calibration certificate and operating instructions in a plastic box, with bearing ring (2), retractable nipple adapter (3) and spacer washer (4)

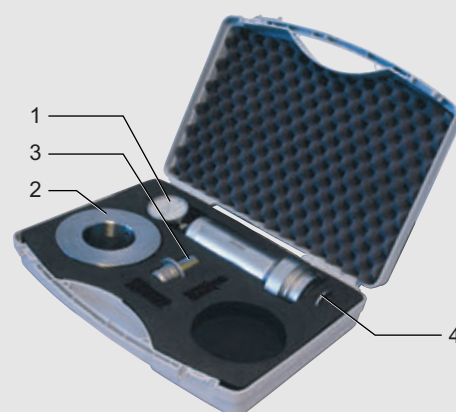

Calibration:

STARK recommends annual calibration of the insertion force tester, the insertion force tester can be sent to STARK for calibration in the original plastic box.



Hydraulic installation aid



Characteristics:

Hydraulic installation aid comprising knurled nut, assembly aid with connection for handpump, expanding mandrel and centring shells.

Application:

Removal/installation of the retaining ring and ball cage, for use in any position, for quick and easy installation.

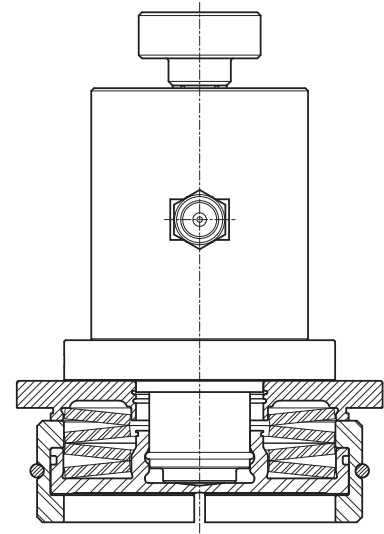

Z 504 012

Order no.	Description	Weight
504 012	Hydraulic installation aid	3.10 kg
801 001	Hydraulic pump	

Installation aid



Characteristics:

Installation aid comprising centring dowel and two centring pins.

Application:

Removal/installation of cup springs and cover.

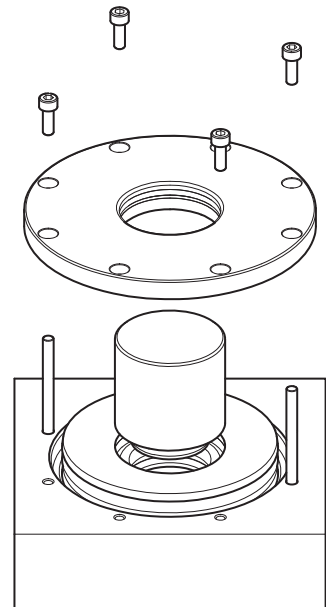

Z 504 009

Order no.	Description	Weight
504 009	Centring aid	0.15 kg





Order number index

105 080 5.5	704 152 4.3	804 281-R 3.6	804 470 3.2
105 090 5.5	704 153 4.3	804 370 2.9	804 471 3.2
105 100 5.2	704 200 6.3	804 371 2.9	804 472 3.3
105 110 5.2	704 201 6.3	804 372 2.9	804 474 3.2
105 120 5.3	704 203 6.4	804 374 2.9	804 476 3.2
105 130 5.3	704 208 6.7	804 375 2.9	804 478 3.3
105 140 5.4	704 210 6.9	804 376 2.10	804 540 1.7
105 150 5.4	704 321 1.4	804 377 2.11	804 799 7.1
504 002 7.5	704 322 1.4	804 378 2.11	804 953 7.4
504 006 7.4	704 323 1.4	804 379 2.10	806 020 1.5
504 009 7.6	704 324 1.4	804 380 2.10	806 021 1.5
504 012 7.6	801 001 7.6	804 381 2.10	806 022 1.6
504 015 6.8	802 201 2.2	804 382 2.10	806 023 1.6
703 009 6.5	802 203 2.3	804 395 2.9	808 200 1.9
703 010 6.5	802 210 2.4	804 398 2.11	808 223 1.8
703 011 6.5	802 211 2.4	804 399 2.11	808 224 1.8
703 012 6.5	802 212 2.4	804 411 4.2	931 059 2.7
703 013 6.5	802 213 2.4	804 419 4.3	931 506 3.6
703 014 6.6	802 251 2.2	804 427 4.4	931 916 3.6
703 015 6.6	802 252 2.3	804 432 4.2	938 006 2.7
703 016 6.6	804 180 2.8	804 433 4.2	938 023 2.7
703 017 6.6	804 193 7.4	804 443 4.4	952 044 2.9
703 018 6.6	804 255 7.2	804 444 4.4	952 126 2.8
703 022 6.5	804 256 7.2	804 445 4.4	952 177 2.8
703 023 6.6	804 258 2.7	804 452 1.2	955 103 2.7
704 099 7.2	804 266 3.4	804 453 1.3	999 104 2.11
704 133 7.3	804 267 3.4	804 456 2.6	
704 150 4.3	804 280 3.7	804 457 2.6	
704 151 4.3	804 281 3.6	804 458 2.6	

Only the original ...



... fits together!

For this reason our customers receive:

- Manufacturer's warranty
- Functional warranty
- Warranty protection
- Selection of fits





STARK Zero Point Clamping Systems



Consultation, planning, design, production, mounting, service - everything from a single source

Cost savings in manufacturing are these days increasingly only possible during machine set-up and by shortening the process times. Your production will be significantly faster by using zero point clamping systems. Key aspects such as focusing on bottlenecks, shortening of cycle times, batch sizes and inventory reduction, to name but a few advantages, are implemented quickly in manufacturing by using STARK zero point clamping systems.

Utilise the extensive experience and flexibility of specialists in zero point clamping technology to optimise your production.

The clamping system SPEEDY classic 2 is robust in use, thanks to its low height and variable spacing it is also very well suited to one-off parts as well as small and large production runs.

The system is easy to handle and the retractable nipples can even be inserted and removed at an angle.

Due to the special retractable nipple contour and the matched radii, the bore is not damaged on insertion in the SPEEDY. No chips can be jammed in the cylindrical bore and due to the optimal application of force - the retractable nipples are fixed positively and highly accurately by spring action - bending or lifting is not possible and as a result high positioning accuracy is guaranteed.

In addition, if required SPEEDY can be equipped with an integrated media duct to carry media, e.g., oil, air or water. Draw-in, position, clamp, release and lift out - SPEEDY classic 2 integrates everything in one intelligent clamping system.

STARK Spannsysteme GmbH

Römergrund 14

6830 Rankweil

Austria

Tel. +43 5522 37 400-0

Fax +43 5522 37 400-700

info@stark-inc.com

www.stark-inc.com