

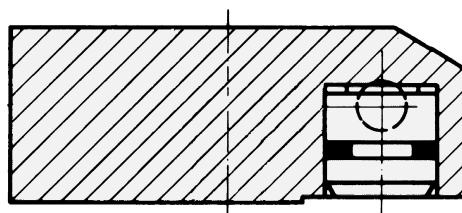

Slideway Locking Cylinders
single acting without spring return
max. operating pressure 500 bar

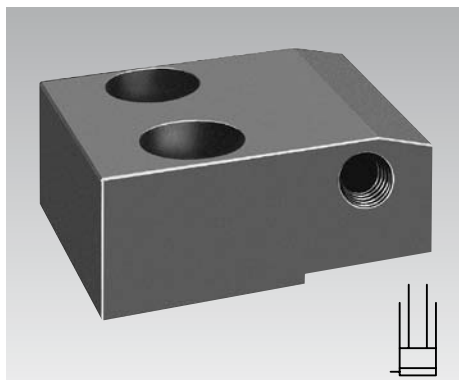

Slideway locking cylinder with 1 piston

Locking force	100 bar	[kN]	4.9
at	500 bar	[kN]	24.5
Piston stroke, max.		[mm]	2

Slideway locking cylinder with 2 pistons

Locking force	100 bar	[kN]	9.8
at	500 bar	[kN]	49.0
Piston stroke, max.		[mm]	2

Application

An economical solution to lock machine tool slideways is the direct locking method by means of hydraulic cylinders, powered from a central power system. Actuating controls of the various locking stations can be integrated with the machine tool control system.

Advantages

- High locking forces with small dimensions
- Max. utilisation of available hydraulic pressure
- Locking pressure can be monitored
- Machine tool interlock as a function of the locking pressure

Material

Piston material: Brass
Cylinder body: free-cutting steel

Important notes

There is no stop to prevent the piston from falling out. Do not pressurise the cylinder, if there is no workpiece for the piston to move against!
Operating conditions, tolerances and other data see data sheet A 0.100. There is no stop to prevent the piston from falling out. Do not pressurise the cylinder, if there is no workpiece for the piston to move against!
Operating conditions, tolerances and other data see data sheet A 0.100.

Hydraulic circuit diagram

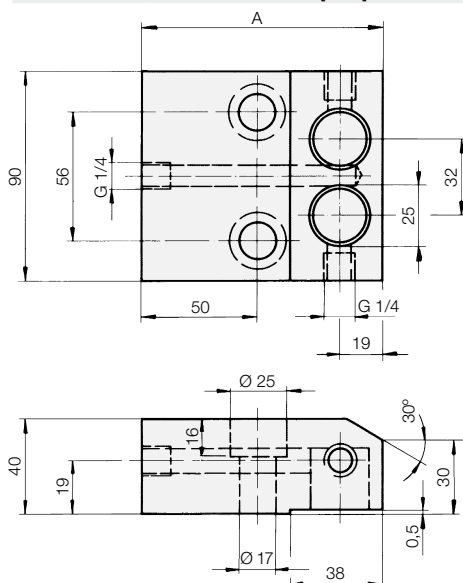
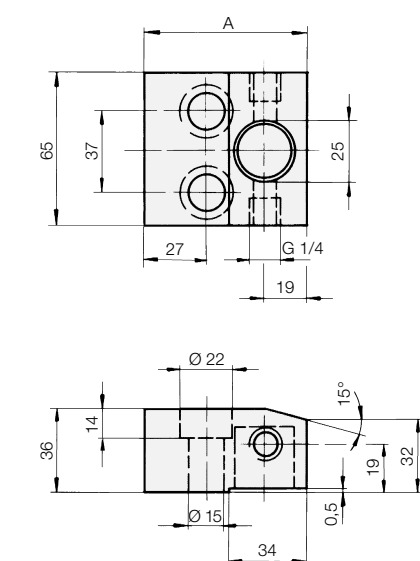
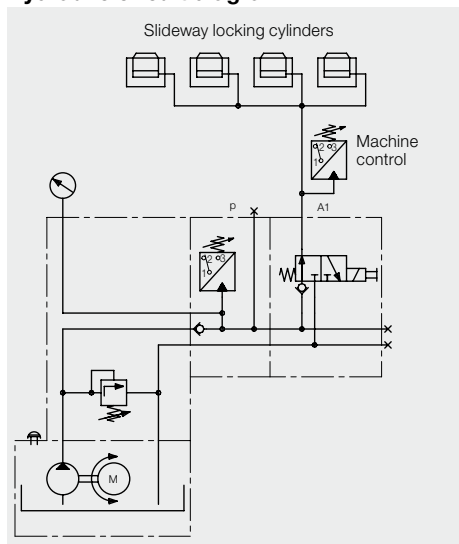

Dimension A = 69 mm	Part-no. 1491-000
Dimension A = 83 mm	Part-no. 1492-000

Dimension A = 104 mm	Part-no. 1493-000
Dimension A = 119 mm	Part-no. 1494-000

Locking of a machine tool slideway

If the slideway locking cylinder cannot be connected to an already existing hydraulic system, we recommend to use one of our power units as per data sheet D 8.0115. These power units are equipped to automatically monitor the locking force, i.e. the pump motor will be shut-off when the pressure in the

hydraulic system has reached a preset value, and cut-in again when pressure drops to 90 % of the preset value. Additionally, machine tool operation can be controlled by a pressure switch such, that it operates only when a pressure value preset on the locking cylinders has been reached.

