



Swing Clamps with Reinforced Swing Mechanism

top flange, position monitoring optional, double acting, pendulum eye/fork head, max. operating pressure 500/160 bar



Advantages

- Introduction of clamping force without side loads
- Compact design
- Double clamping arm facilitates multiple clamping of similar workpieces
- Pendulum eye for high clamping forces
- Fork head for simple clamping arms
- Alternatively pipe thread or drilled channels
- Reinforced swing mechanism
- FKM wiper standard
- Available with position monitoring

Connecting possibilities

- Pipe thread
- Drilled channels

Metallic wiper optional

Function

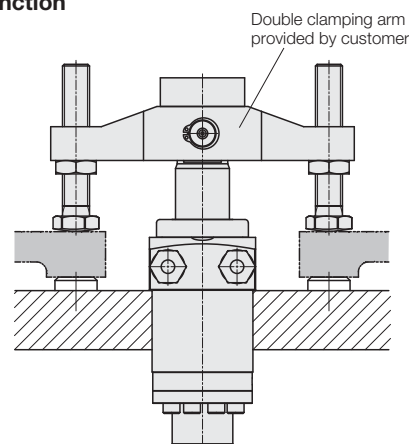

Application

Hydraulic swing clamps are used for clamping of workpieces, when it is essential to keep the clamping area free of straps and clamping components for unrestricted workpiece loading and unloading.

The version with pendulum eye or fork head allows simultaneous clamping of two workpieces with half clamping force.

Function

The hydraulic swing clamp is a double-acting pull-type cylinder where a part of the total stroke is used to swing the piston.

Swing direction

The swing clamps are available with clockwise or counterclockwise swing motion. Off-position is the extended piston position.

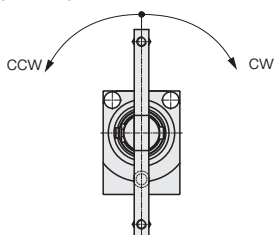

Process safety

To improve the process safety when using heavy double clamping arms the swing mechanism has been reinforced and an overload protection device has not been realised.

During clamping the reinforced swing mechanism endures a collision of the clamping arm with the workpiece up to a pressure of 100 bar.

All versions are also available with a switch rod at the cylinder bottom. The control cams are mounted at this rod to control the clamping and unclamping position with limit switches or pneumatically.

Adaptable position monitorings for inductive or pneumatic control are available as accessory (page 4).

Description

The piston end of this swing clamp is designed as pendulum eye or fork head. By means of a double clamping arm 2 workpieces can be clamped at the same time.

For both versions a springy element is required in order to maintain the double clamping arm in the unclamped position in horizontal position.

Pendulum eye

The sturdy pendulum eye can transmit high clamping forces up to a max. operating pressure of 500 bar. The double clamping arm has to be dimensioned according to the load.

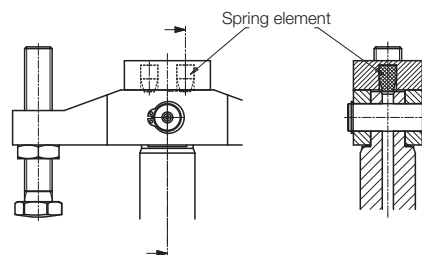

Fork head

The fork head allows a max. operating pressure of 160 bar. Advantageous is the fact that relatively simple clamping arms can be manufactured from flat materials.

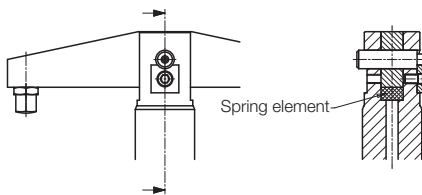

Option - metal wiper

The optionally available metallic wiper protects the FKM wiper against mechanical damage due to big or hot swarfs.

Swing clamp with optional position monitoring (accessory)

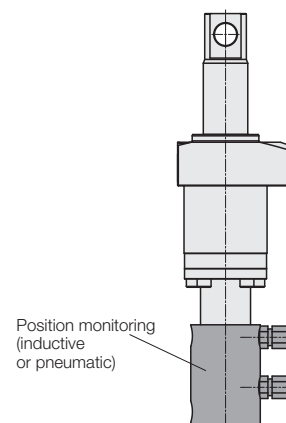

Important notes

Danger of injury

Hydraulic clamping elements generate high clamping forces. Considerable injuries can be caused to fingers in the effective area of the double clamping arm.

Remedy: mount protection devices.

Operating conditions, tolerances and other data see data sheet A 0.100.

Clamping arm

Due to the missing overload protection device a collision with the clamping arm during loading and unloading of the fixture must be avoided. Remedy: mount position adaptor.

The double clamping arm in clamping position should preferably be at right angles to the piston axis to avoid overload of the spring element. Both contact bolts must only contact the workpiece after completion of the swing stroke.

Please consider: When doubling the length of the clamping arm the mass moment of inertia is increased eight fold. Therefore the flow rate has to be throttled correspondingly.

Dimensions Code for part numbers

Pendulum eye 189X-133X (500 bar) without switch rod

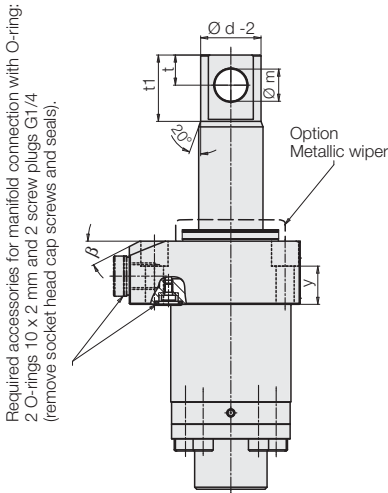

Required accessories for manifold connection with O-ring:
2 O-rings 10 x 2 mm and 2 screw plugs G1/4
(remove socket head cap screws and seals).

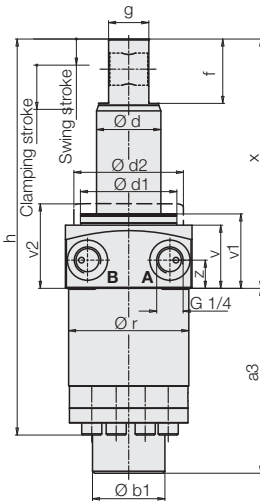

Fork head 189X-153X (160 bar)

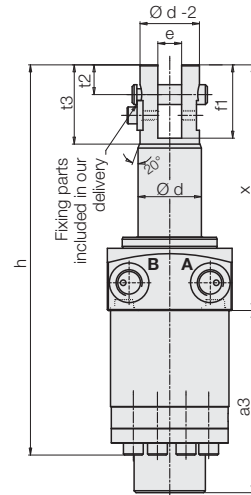

A = Clamping
B = Unclamping

With switch rod 189X-1X2X

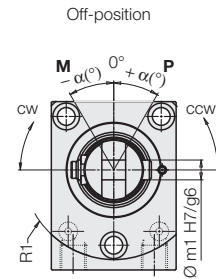
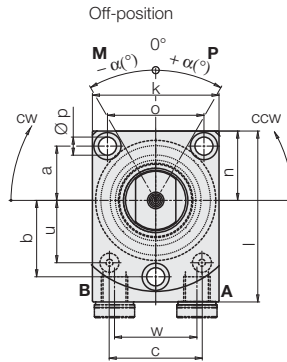
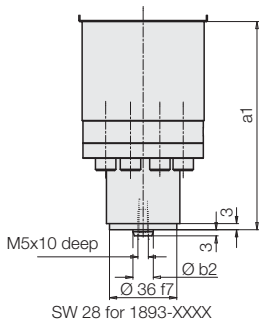

Accessory: position monitoring see page 4.

Code for part numbers

1 8 9 X - 1 X X X - X X X X

Off-position (unclamped extended position)

The fixing of the clamping arm with pendulum eye or fork head does not allow an adjustment of the off-position as possible in case of cone fixation. Therefore the desired off-position has to be indicated when placing the order. The angle α can be selected in steps of 5°.

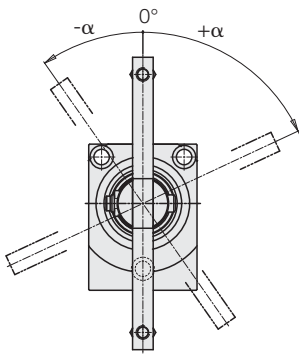

Piston rod $\varnothing d$
3 = 20 mm
5 = 32 mm

3 = Pendulum eye
5 = Fork head
2 = with switch rod
3 = without switch rod

M = Metallic wiper, mounted
Angle α for off-position
00 up to 90: 0° up to max. 90°
(graduation of 5°)

P (Plus) = $+\alpha$ see dimensional drawing
M (Minus) = $-\alpha$
0 = $\alpha = 0^\circ$

0 = 90° clockwise swing motion
1 = 90° counterclockwise swing motion
2 = 75° clockwise swing motion
3 = 75° counterclockwise swing motion
4 = 60° clockwise swing motion
5 = 60° counterclockwise swing motion
6 = 45° clockwise swing motion
7 = 45° counterclockwise swing motion
8 = 30° clockwise swing motion
9 = 30° counterclockwise swing motion

Swing angle $\pm 1^\circ$

1. Example of ordering

Piston rod diameter = 20 mm,
pendulum eye,
without switch rod,
swing angle 90° clockwise,
off-position 0°,
metallic wiper mounted
Part-No.: 1893-1330-000M

2. Example of ordering

Piston rod diameter = 32 mm,
fork head,
with switch rod,
swing angle 60° counterclockwise,
off-position -30°,
metallic wiper mounted
Part-No.: 1895-1525-M30M

Technical data

		1893-	1895-
Clamping stroke	[mm]	25	22
Swing stroke	[mm]	9	13
Total stroke	[mm]	34	35
Operating pressure, min.	[bar]	30	30
Max. oil flow rate	[cm ³ /s]	8	20
Effective piston area			
Clamping	[cm ²]	1.76	4.52
Unclamping	[cm ²]	4.9	12.56
Oil volume/stroke	[cm ³]	6	15.8
Oil volume/return stroke	[cm ³]	16.7	44
β	[°]	12	27
a	[mm]	20	27
a1	[mm]	94	102
a3	[mm]	84	92
b	[mm]	30	38
\varnothing b1	[mm]	22	36
\varnothing b2 f7	[mm]	10	10
c	[mm]	32	46
\varnothing d	[mm]	20	32
\varnothing d1	[mm]	38	48
\varnothing d2	[mm]	42	54.5
e + 0.1	[mm]	8	12
f	[mm]	20	32
f1	[mm]	26	37
g f7	[mm]	12	20
h	[mm]	182	197
k	[mm]	50	63
l	[mm]	70	85
\varnothing m H7	[mm]	10	16
\varnothing m1 H7	[mm]	6	10
n	[mm]	26.5	34.5
o	[mm]	37	48
\varnothing p	[mm]	6.6	9
\varnothing r -0.1	[mm]	44.8	59.8
R1	[mm]	36	45.3
t	[mm]	9	15
t1	[mm]	21	33
t2	[mm]	10	15
t3	[mm]	29	40
u	[mm]	26.5	31
v	[mm]	26.4	31.4
v1	[mm]	31	37
v2	[mm]	36	42
w	[mm]	28	41
x	[mm]	104.5	124
y	[mm]	18	19
z	[mm]	14	14

Accessories

Metallic wiper, complete (customer assembly)	0341-107	0341-100
O-ring 10 x 2	3000-347	3000-347
Screw plug G 1/4	3610-264	3610-264

Clamping force F as a function of the operating pressure p

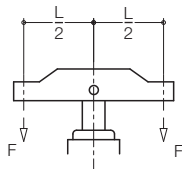

1893-1XXXX

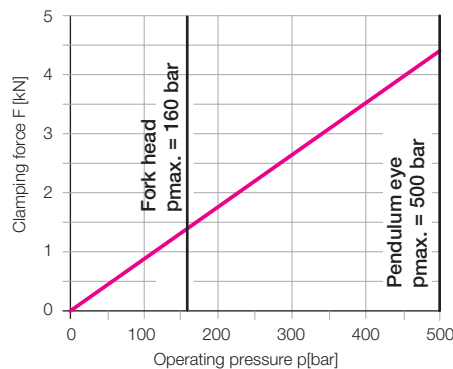

1895-1XXXX

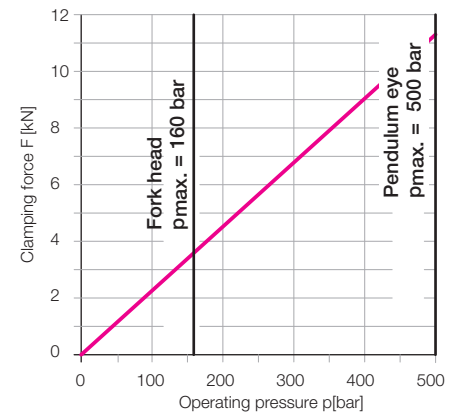

Accessory - Position Monitorings

Delivery

The position monitorings are not delivered mounted at the swing clamp.

Fixing screws and signal sleeve are included in the delivery.

Electrical position monitorings are delivered with 2 inductive proximity switches and 2 right angle plugs.

The housings can be mounted rotated by 2x180° (1893-) or 8x45°.

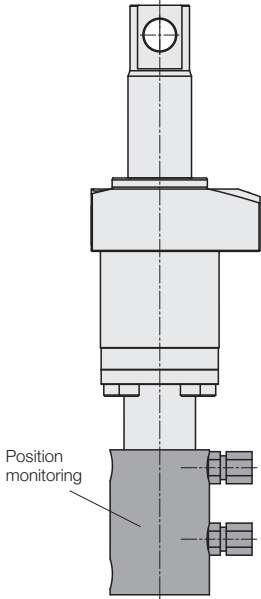

Pneumatic position monitoring

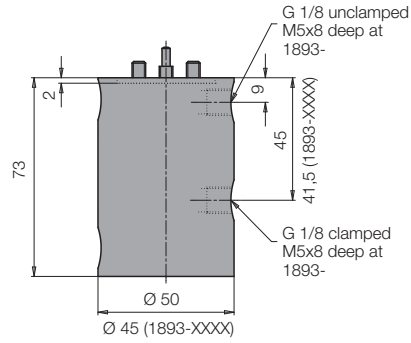

	for 1893-	for 1895-
Part-no.	0353-867	0353-808

Function chart

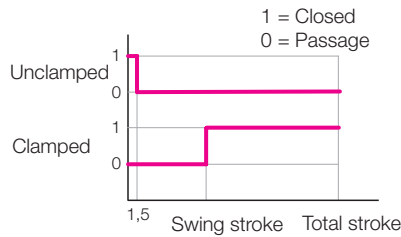

Electrical position monitoring

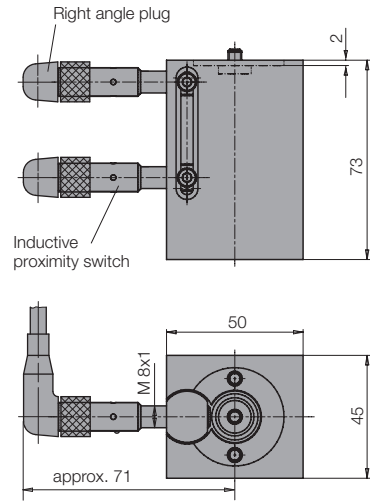

	for 1893-	for 1895-
Part-no.	0353-868	0353-814

Function chart

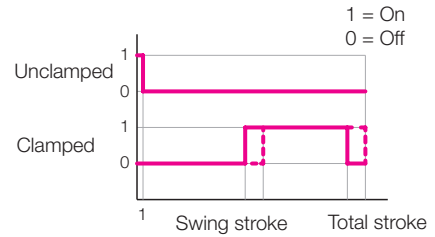

Technical data

for proximity switches

Voltage	10...30 V DC
Residual ripple max.	15 %
Constant current max.	200 mA
Switching function	interlock
Output	PNP
Body material	stainless steel
Code class	IP 67
Environmental temperature	-25...+70°C
Connection	plug
Length of cable	5 m
LED function display	Yes
Protected against short circuits	Yes