

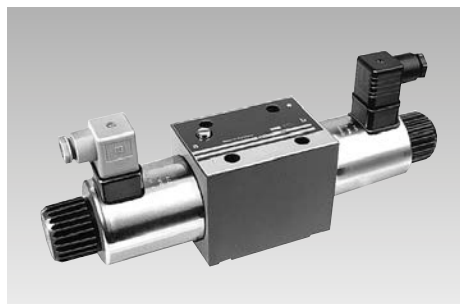

Directional Control Valves ND 10
max. operating pressure 315 bar

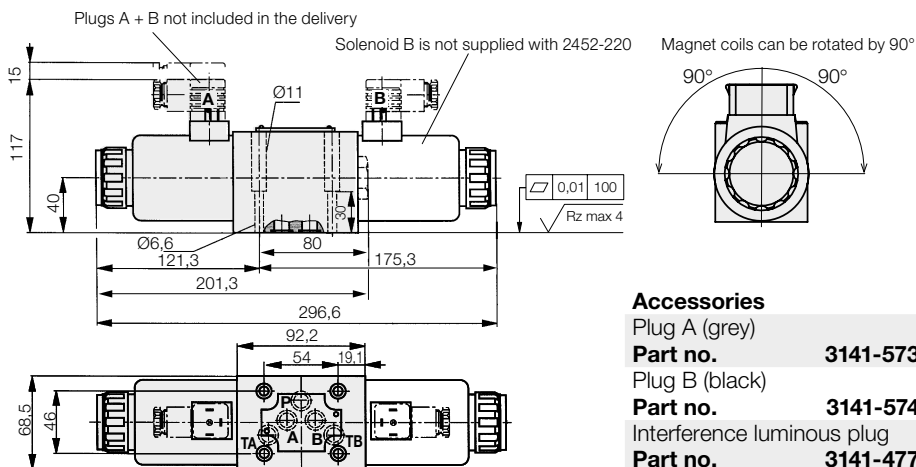

4/3 directional control valve with 2 solenoids



General data

Type	Direct-acting spool valve
Oper. specification	DC solenoid, submersed in oil with emergency hand actuation
Connecting dimensions	Pinhole image as per DIN 24340 Form A, CETOP 4.2-4.3, ISO 4401
Type of connection	Subplate mounted
Sealing	4 sealing rings 13x16.1x2 NBR Part no. 3002-069 (are supplied)
Type of mounting	4 socket head cap screws M 6x40 -12.9 DIN EN ISO 4762 Part no. 3301-200
Seating torque	15.5 Nm
Mounting position	any

Hydraulic data

Fluid	Hydraulic oil as per DIN 51524
Viscosity range	(2.8 ... 500) x 10 ⁻⁶ m ² /s
Temperatur	-30...+80 °C
Operating pressure	Ports A, B, P ... 315 bar
Return pressure	Port T ... 210 bar
Leakage rate	... 30 cm ³ /min at 100 bar $v = 36 \times 10^{-6}$ m ² /s and t = 50 °C
Flow rate	... 120 l/min
Flow curve	measured at $v = 36 \times 10^{-6}$ m ² /s and t = 50 °C

Electric data

Supply voltage	24 V DC
Power input	35 W
Duty cycle	100%
Switching time	on: 45-60 ms off: 20-30 ms
Max. cycles	... 15000 Sch/h
Ambient temperature	-30...+50 °C
Code class	IP 65 as per DIN 40050
Connection	single plug connection as per DIN EN 175 301-803 and ISO 4400

Other voltages and actuations available on request.

Description	Symbol N°	Symbol	Weight [kg]	Part no.
4/2 directional control valve	C		4,3	2552-220
4/3 directional control valve	E		5,9	2553-220
4/3 directional control valve	G		5,9	2555-220
4/3 directional control valve	J		5,9	2557-220
4/3 directional control valve	H		5,9	2558-220

Δ p/Q-characteristic curves
 $v = 35$ mm²/s for standard version

Symbol N°	Curve N°		Curve N°		PT
	PA	BT	PB	AT	
C	3	5	3	4	-
E	1	4	1	4	-
G	3	7	3	6	9
J	1	3	1	3	-
H	1	7	1	6	3

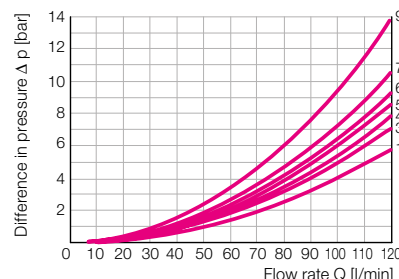

When determining pressure drop it should be noted that for double-acting cylinders with a piston surface ratio of e.g. : = 1.6 a return flow rate 1.6 times the flow rate of the power unit must be used.
Application limit: Function limit with warm solenoids and 10% undervoltage.

Switching limits for valves in standard version

The curves refer to applications with symmetrical flow of the valve. In the case of unsymmetrical flow (e.g. one passage is not used) reduces values can result. The values have been determined without switching time adjustment. With switching time adjustment these values are reduced by up to 20 % depending on the adjusting value.

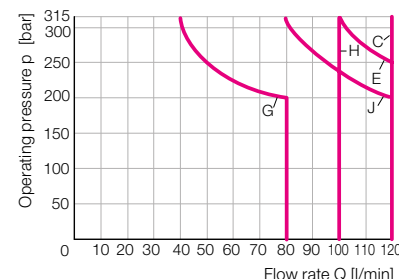

Note: The switching function of the valves depends on the filtering, due to the sticking effect. If the indicated, admissible flow values are to be used to the maximum, full flow filtering to 25 μm is recommended. Besides this, the values are only valid for standard use with 2 flow directions, e.g. from P to A with simultaneous return flow from B to T.

Single mounting plate G 1/2
Part no. 2530-100
 Connecting ports at the back

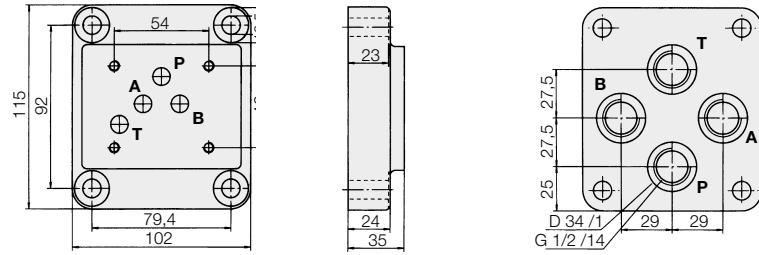

Series mounting plates	Part no.
Connecting plate G 1/2	2530-710
Mounting plate for un-pressurised cycles	2530-601
Series mounting plate G 1/2	2530-402

Nuts M8, safety washers, plugs and O-rings are supplied with the connecting plates. Threaded bolts M8 x 1000 have to be ordered separately. **Part no. 3300-343**
 The length of the threaded studs results from the number of series mounting plates + 20 mm.

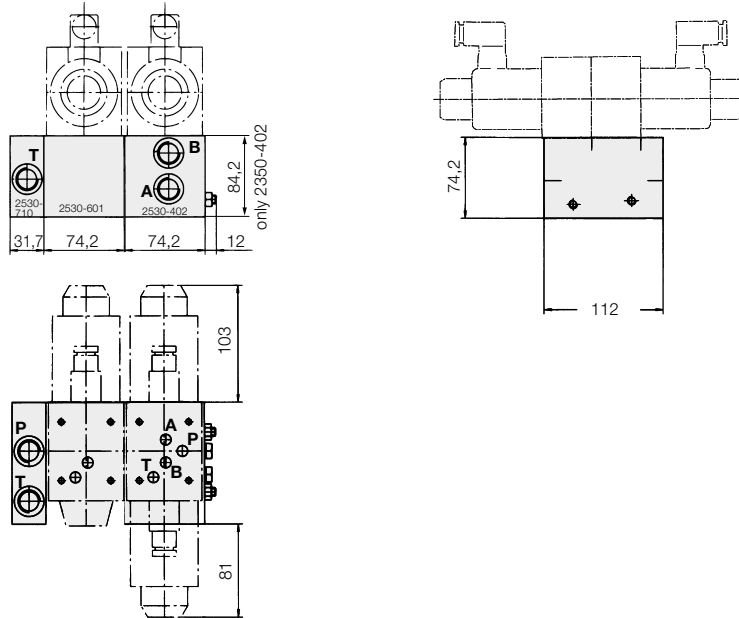

Twin flow control non-return valve
Part no. 2957-402

This valve regulates the flow rate in both port connections. It is flanged between directional control valve and mounting plate. For this longer fixing screws are necessary: 4 off M 6x90 -12.9 DIN EN ISO 4762, **Part no. 3301-202**

Through the separate O-ring plate, which always has to lie on the mounting plate, it is possible to control either the inflow or return flow by turning the valve round the x-x axis (see hydraulic circuit diagram).

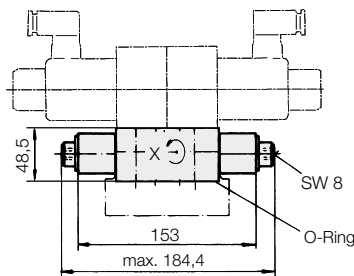

Presentation in the hydraulic circuit diagram

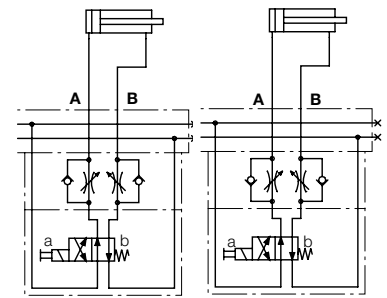

Inflow control Return-flow control

Twin non-return valve
Part no. 2951-590

This valve provides a leakage-free oil seal of one or two port connections. It is flanged between directional control valve and mounting plate. For this longer fixing screws are necessary: 4 socket head cap screws M 6x90 -12.9 DIN EN ISO 4762, **Part no. 3301-202**. The surface ratio is 1:2.78.

A leakage-free oil seal of both connections is not possible when using 4/3 directional control valves 2553-220, 2555-220 (see hydraulic circuit diagram).

Further accessories

For building on of complete hydraulic controls to power units as per data sheet D 8.031, further interlinking elements are available. We would be pleased to submit a quotation tailored to your particular application.

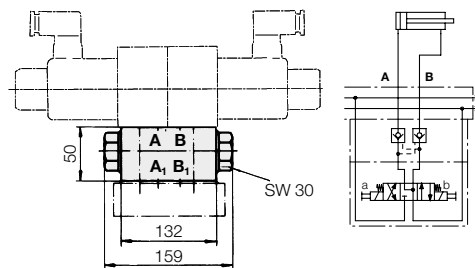

Presentation in the hydraulic circuit diagram

Presentation of twin non-return valve and twin flow control non-return valve

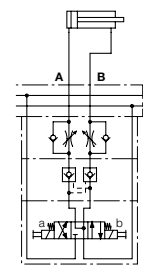

For the installation of twin non-return valve and twin flow control non-return valve in combination with a spool valve longer fixing screws are necessary: M 6 x 140 DIN EN ISO 4762 -12.9, **Part no. 3301-527**