



**Pneumatic Swing Clamp**  
for adjustable magnetic sensors  
double acting, max. operating pressure 7 bar



The opposite figure shows a pneumatic swing clamp  
Clamping arm and flange are accessories

**Pneumatic swing clamp with accessories**

1. Clamping arm (page 3)
2. Magnetic sensor with hose clamp (page 4)
3. Y-cable (see page G 2.140)

**Application**

Pneumatic swing clamps are used for applications which require only low clamping forces. The installed magnetic piston allows monitoring of clamping and unclamping position.

**Description**

When pressurising the element, the clamping arm swings and lowers by 90° to the clamping position and then lowers to the clamping point. The position monitoring gives the required information regarding the position of the piston, but not regarding the position of the clamping arm. Monitoring is made by electronic sensors (see accessory) which detect the magnetic field of the magnetic piston. The switching points can be continuously adjusted by displacement of the magnetic sensors.

**Special features**

When adjusting the clamping screw it has to be considered that for the swing motion a part of the total stroke is required.

Make sure that the swing motion can be effected without any interference.

When using special clamping arms with other lengths, the corresponding operating pressures as shown in the clamping force diagram must not be exceeded.

**Pneumatic accessories**

see data sheet J 7.400.

**Installation**

On fixtures flange-type swing clamps (flange is an accessory) or threaded versions with corresponding collar nuts can be easily adjusted to different workpiece heights.

**Material**

The swing clamps are supplied in corrosion resistant quality. Guide bushing, housing, piston, and flange are made of hardcoated aluminium.

The piston rod is made of corrosion resistant steel.

**Important note**

Operating of these pneumatic elements has to be effected with an additional service unit in order to guarantee that the clamping elements are supplied with correctly prepared compressed air.



**Connecting example**

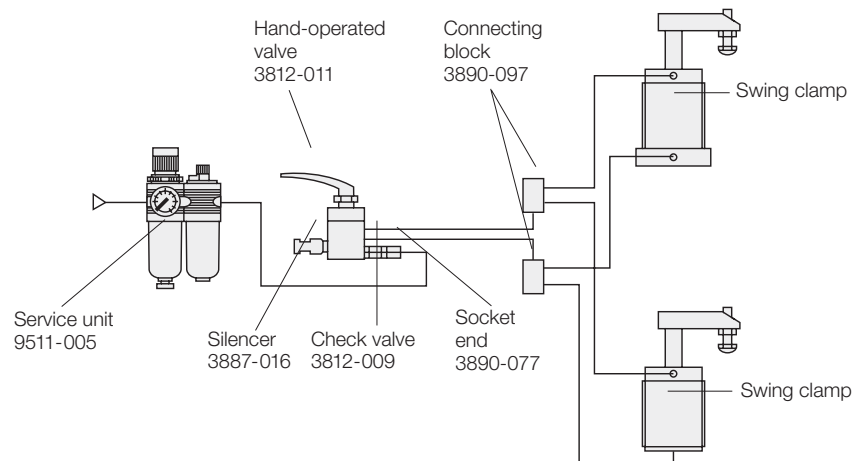

## Technical data

### Dimensions • Effective clamping force

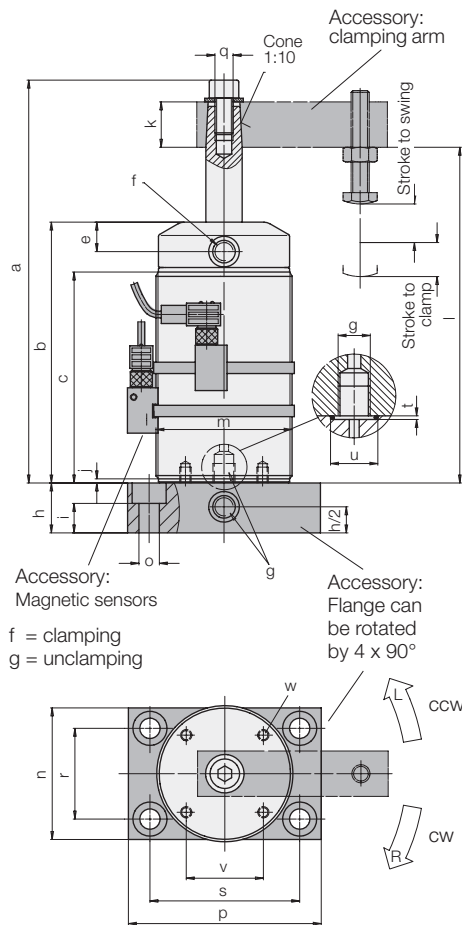

Piston Ø	[mm]	20	32	40	50	63
Piston rod Ø	[mm]	8	12	16	20	25
Stroke to swing	[mm]	7.5	9.5	17	18	23
Stroke to clamp	[mm]	7	9	15	15	18
Pulling force at 4 bar	[N]	105.5	276.4	422.2	659.7	1050.5
*air pressure 5 bar	[N]	131.9	345.5	527.7	824.6	1313.1
6 bar	[N]	158.3	414.6	633.3	989.6	1575.8
Min. operating pressure	[bar]	3				
Max. operating pressure	[bar]	7				
Angle of rotation	[°]	90° ± 2°				
Weight	[kg]	0.20	0.30	0.70	0.90	2.1
a	[mm]	114.3	133.1	182.6	198.5	240.5
b	[mm]	75	86.5	115	125	156
c	[mm]	58.5	67.5	93	101	124
e	[mm]	9.5	12	13	13	17
f	[mm]	M5	M5	G 1/8	G 1/8	G 1/4
g	[mm]	M5	M5	G 1/8	G 1/8	G 1/4
h	[mm]	12	16	22	22	25
i	[mm]	5.5	9.5	13	13	14
j	[mm]	2	2	2	2	2
□ k	[mm]	12	16	20	25	30
l	[mm]	97.5	109.5	153	159	198
m	[mm]	M30x1.5	M40x1.5	M50x1.5	M60x1.5	M80x1.5
n	[mm]	30	38	50	58	75
o	[mm]	6.6	6.6	9	9	11
p	[mm]	60	65	80	85	110
q	[mm]	M4	M6	M8	M12	M10
r	[mm]	17	23	30	40	55
s	[mm]	43	50	60	66	88
t	[mm]	1.1	1.1	1.1	1.1	1.5
Ø u	[mm]	9.8	9.8	14.3	14.3	19.8
□ v	[mm]	14.2	17.6	26.88	34	38.9
w	[mm]	M4x5.5	M5x5	M5x7	M5x7	M8x10
Clockwise rotation	<b>Part-no.</b>	<b>1873-305</b>	<b>1874-303</b>	<b>1875-303</b>	<b>1876-303</b>	<b>1877-303</b>
Counterclockwise rotation	<b>Part-no.</b>	<b>1873-405</b>	<b>1874-403</b>	<b>1875-403</b>	<b>1876-403</b>	<b>1877-403</b>
Accessory: flange	<b>Part-no.</b>	<b>0345-403</b>	<b>0345-404</b>	<b>0345-405</b>	<b>0345-406</b>	<b>0345-407</b>

\* Effective clamping force see diagram

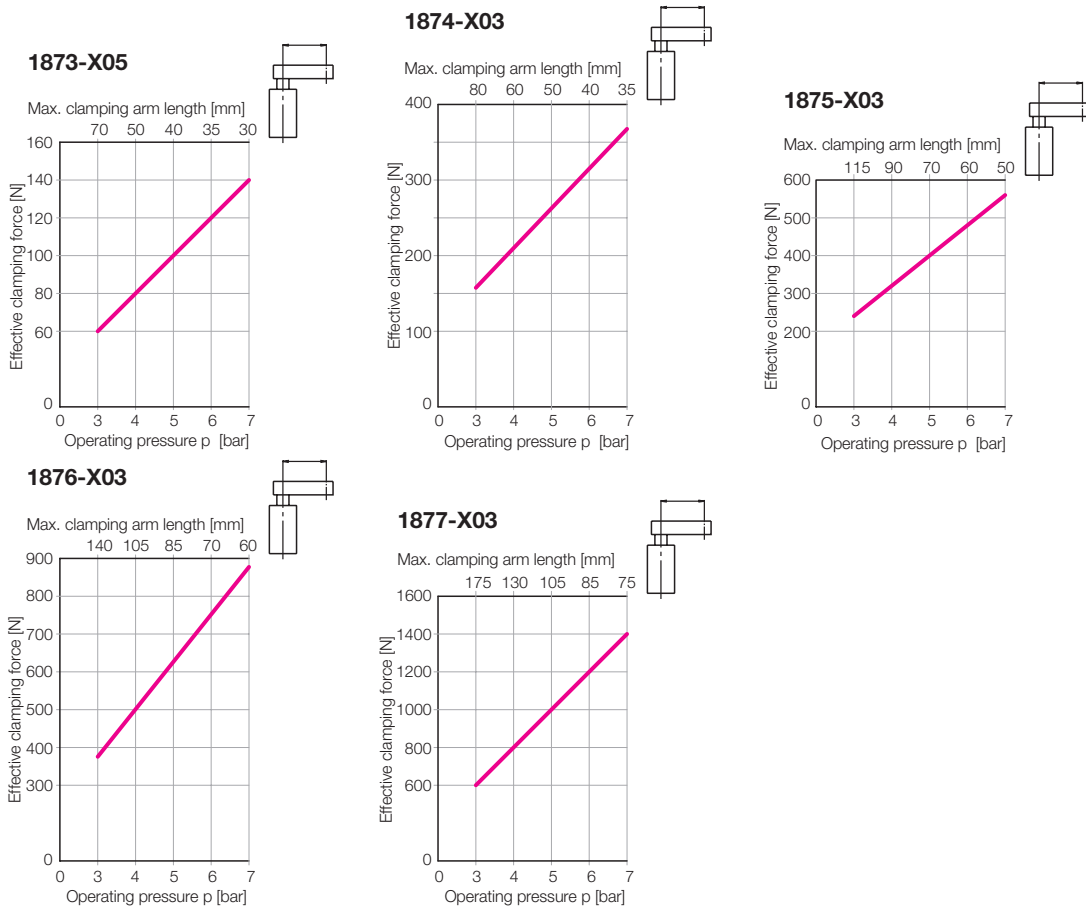

## Accessory: Clamping arms • Mounting parts

### Seat of clamping arm (dimensions)

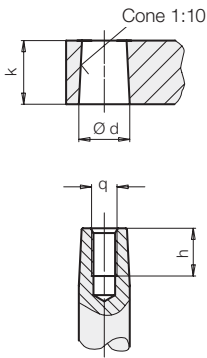

Swing clamp	$\varnothing d^{+0.05}$	$\square k$	h	q
1873-X05	7.85	12	9	M 4
1874-X03	11.85	16	15	M 6
1875-X03	15.85	20	19	M 8
1876-X03	19.85	25	18	M 12
1877-X03	24.85	30	25	M 10

### Clamping arm

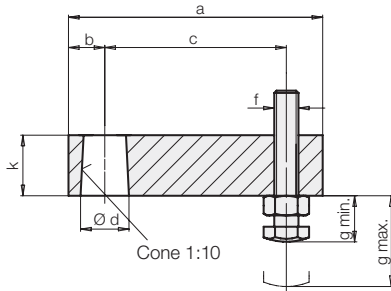

Swing clamp	a	b	c	$\varnothing d^{+0.05}$	f	g min.	g max.	$\square k$	Part-no.
1873-X05	42	7	30	7.85	M 4	8	20.5	12	0187-324
1874-X03	52	10	35	11.85	M 6	12	17.5	16	0187-424
1875-X03	70	12	50	15.85	M 6	12	28.5	20	0187-524
1876-X03	82	14	60	19.85	M 8	15	25	25	0187-624
1877-X03	104	18	75	24.85	M10	19	36.5	30	0187-724

### Clamping arms for special versions

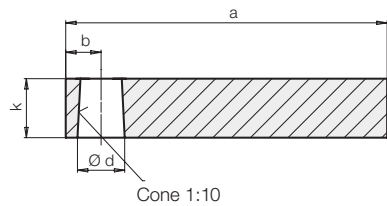

Swing clamp	a	b	$\varnothing d^{+0.05}$	$\square k$	Part-no.
1873-X05	62	7	7.85	12	3548-355
1874-X03	72	10	11.85	16	3548-356
1875-X03	95	12	15.85	20	3548-357
1876-X03	116	14	19.85	25	3548-353
1877-X03	143	18	24.85	30	3548-358

### Flanged nut

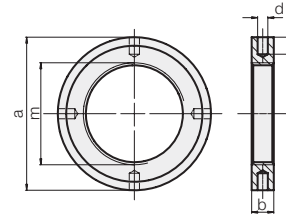

Swing clamp	$\varnothing a$	b	c	$\varnothing d$	m	Part-no.
1873-X05	50	10	7	4 x 5	M 30 x 1.5	3527-071
1874-X03	62	12	8	4 x 6	M 40 x 1.5	3527-040
1875-X03	75	13	10	6 x 6	M 50 x 1.5	3527-041
1876-X03	90	13	10	6 x 6	M 60 x 1.5	3527-042
1877-X03	115	16	12	6 x 8	M 80 x 1.5	3527-043

### Threaded nut

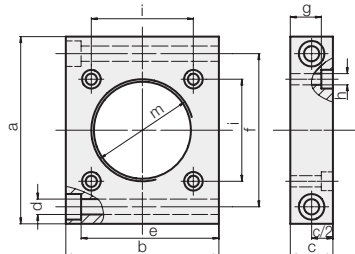

Swing clamp	a	b	c	$\varnothing d$	e	f	g	$\varnothing h$	i	m	Part-no.
1873-X05	65	55	15	5.5	49.3	50	10.4	4.5	30	M30x1.5	3527-073
1874-X03	80	65	15	5.5	59.3	60	10.4	4.5	40	M40x1.5	3527-044
1875-X03	95	75	20	6.6	68.2	75	14.3	5.5	50	M50x1.5	3527-045
1876-X03	110	90	25	9	81	90	18.2	6.6	60	M60x1.5	3527-046
1877-X03	140	120	25	11	109	115	16	9	75	M80x1.5	3527-047

### Contact bolts, dome head

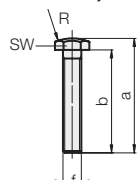

Swing clamp	a	b	f	R	SW	Part-no.
1873-X05	32.5	30	M 4	15	7	3614-141
1874-X03	33.5	30	M 6	20	10	3614-137
1875-X03	48.5	45	M 6	20	10	3614-138
1876-X03	50	45	M 8	20	13	3614-139
1877-X03	66.5	60	M 10	35	17	3614-140

## Accessory Magnetic sensors

Compared with traditional reed switches the electronic magnetic sensors offer the following advantages:

- Indifference to shock and vibration
- Bounce-free output signal
- Only one switching point
- Wear resistant
- Protection against reverse battery
- Protected against short circuits

Electric connection is made as per traditional inductive proximity switches.

Up to four magnetic sensors can be connected in series.

The magnetic sensor is mounted at the swing clamp body with a hose clamp.

### Electronic magnetic sensor

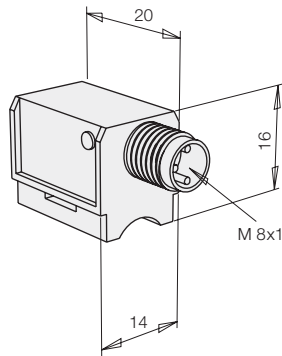

### Connecting cable with right angle plug

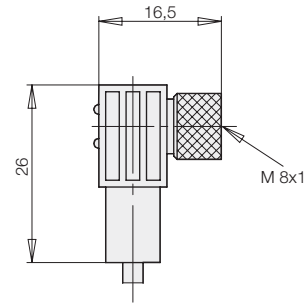

### Connecting scheme

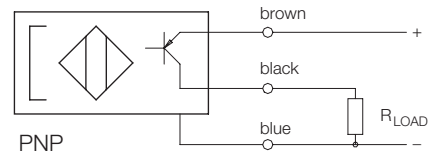

Hose clamp for swing clamp	Part-no.
1873-X05	<b>3829-132</b>
1874-X03	<b>3829-133</b>
1875-X03	<b>3829-120</b>
1876-X03	<b>3829-134</b>
1877-X03	<b>3829-135</b>

Technical characteristics	Electronic magnetic sensor	Connecting cable with right angle plug
Cylinder body material	PA 12 - GF 30; yellow	
Voltage	10 – 30 V DC	10 – 30 V DC
Residual ripple	max. 10%	
Current load $I_{LOAD}$	200 mA	
Current consumption	< 2 mA	
Voltage drop (max. load)	< 1.8 V	
Output	pnp, interlock	
Protected against short circuits	yes	
Protection against reverse battery	installed	
Switching frequency	1 kHz	
Switching hysteresis	< 1 mm	
Protection as per DIN 40050	IP 67	IP 67
Environmental temperature	-25°C up to +70°C	-25°C up to +90°C
Plug connection	M8 x 1 plug	M8 x 1 plug
LED	Function display (red)	Voltage (green) Function display (yellow)
Cable, length of cable		PUR, 5 m
<b>Part-no. (1 off)</b>	<b>3829-119</b>	<b>3829-099</b>