

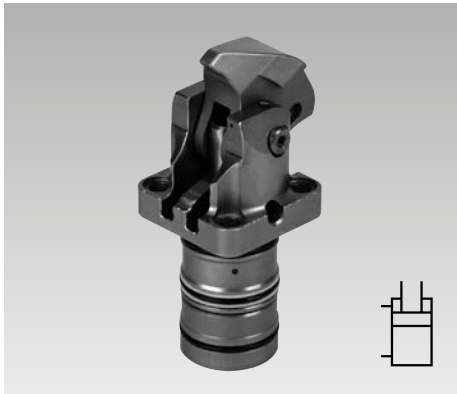

Compact Clamps

Cartridge type, pneumatic position monitoring optional,
 double acting, max. operating pressure 250 bar



Advantages

- Minimum dimensions
- Partially immersed body
- Mounting without pipes
- Metallic wiper edge for piston rod
- Clamping lever can be swivelled into small recesses
- Workpiece clamping without any side loads
- Unimpeded loading and unloading of the clamping fixture
- Long clamping lever adaptable to the workpiece
- Mounting position: any

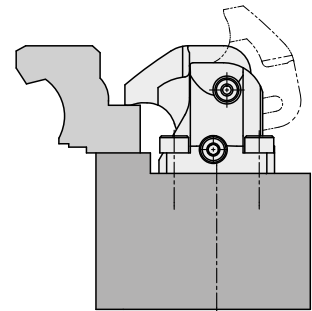

Application

Compact clamps are designed for application in hydraulic clamping fixtures where oil supply is effected through drilled channels in the fixture body. Due to the minimum space required, the compact clamp is especially suitable for clamping fixtures with little space for the installation of hydraulic clamping elements.

A clamping recess in the workpiece a little bit wider than the clamping lever is sufficient as clamping surface. Typical applications are:

- Rotary indexing fixtures in horizontal and vertical machining centres
- Clamping fixtures for machining of several sides and complete machining
- Multiple clamping fixtures with many workpieces that are closely arranged
- Test systems for motors, gears, etc.
- Assembly lines

Installation and connecting possibilities

Drilled channels with cover

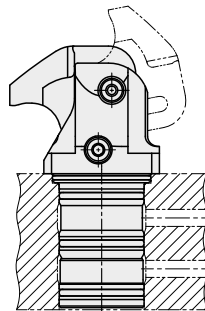

Pipe thread with accessory Mounting body

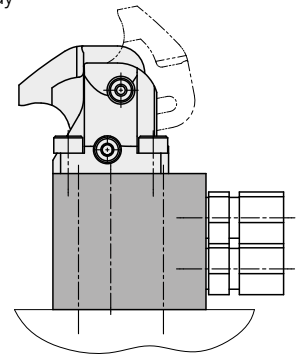

without cover

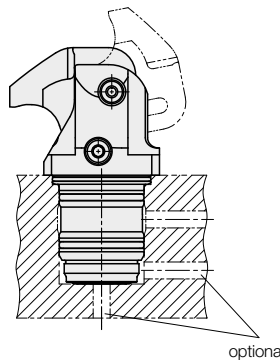

Long clamping lever (blank)

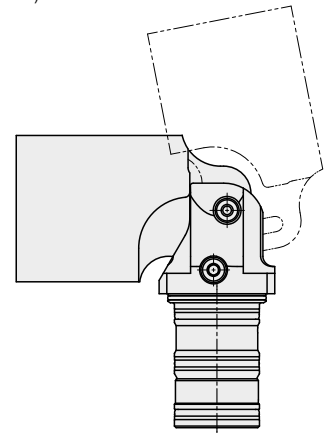

Description

The hydraulic compact clamp is a double-acting pull-type cylinder where a part of the linear stroke is used to swing the clamping lever onto the workpiece.

The version with cover is inserted in open bore holes and enables the smallest possible building height.

The version without cover requires a closed pocket hole.

Available versions

1. With pneumatic clamping monitoring 180X-1XX

The clamping monitoring signals:

"The clamping lever is within the usable clamping range and the workpiece is clamped with minimum clamping force (min. 70 bar)."

2. With pneumatic unclamping monitoring 180X-1XXA

The unclamping monitoring signals:

"The clamping lever is within the unclamping range, starting approx. 10° before the final position."

3. Without position monitoring 180X-1XXB

Pneumatic position monitoring see page 4

Important notes

(see page 3)

Pneumatic position monitoring

Clamping position or Unclamping position

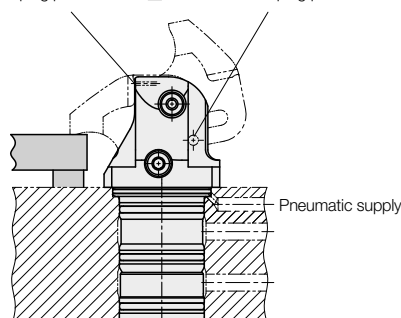

Application example



Clamping of a cast part

Dimensions

With cover Short clamping lever

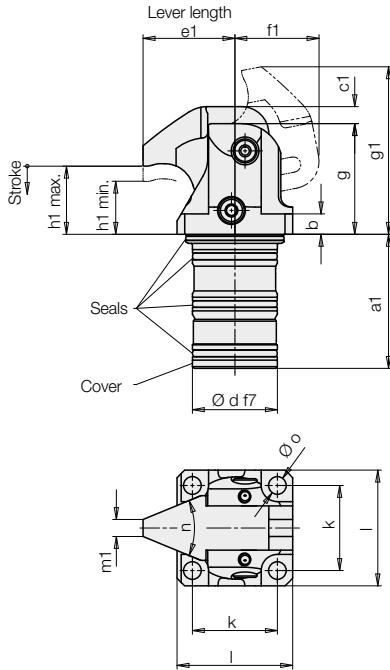

Long clamping lever (blank)

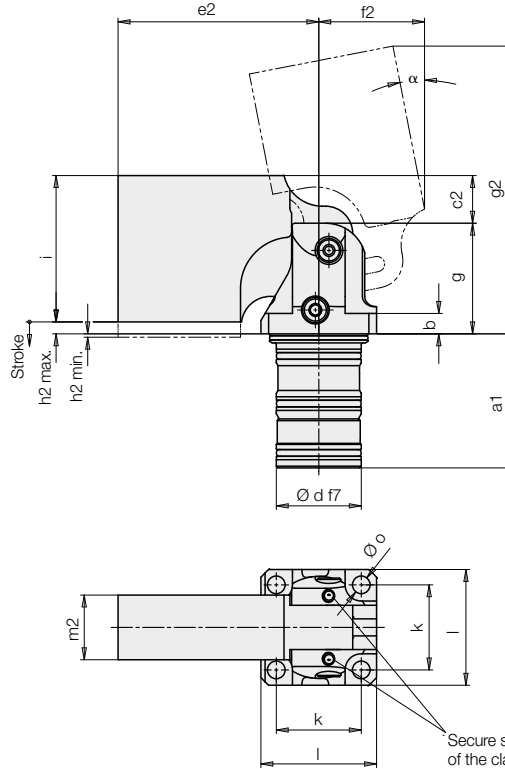

Without cover

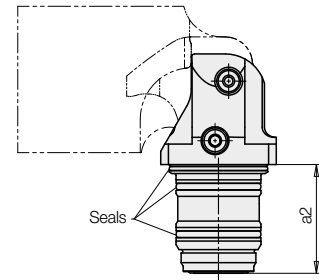

Pneumatic position monitoring see page 4

Bore hole open (with cover)

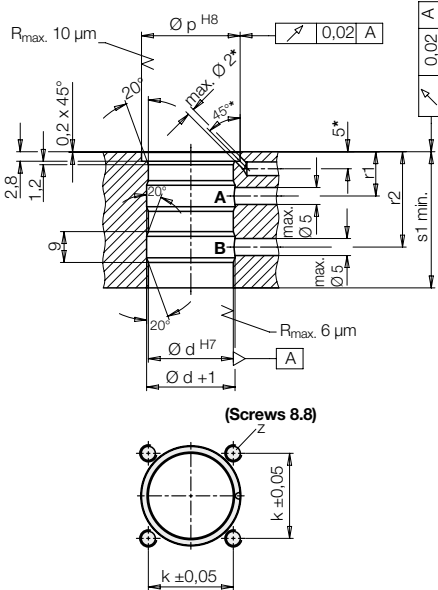

Material

Body: hardened, stainless
Clamping lever: short HRc 48 – 55, stainless; long (blank) X37 CrMoV5-1 hardened and tempered HRc 40 and nitrated
Seals: NBR and PUR (max. 80°)

Accessories

Mounting body (see page 4)

A = Clamping
B = Unclamping

- * Bore holes for pneumatic clamping and unclamping monitoring, only if required.
- ** Dimension s2 ± 0.1 must be met, otherwise the piston will strike the bottom of the pocket hole.

Pocket hole (without cover)

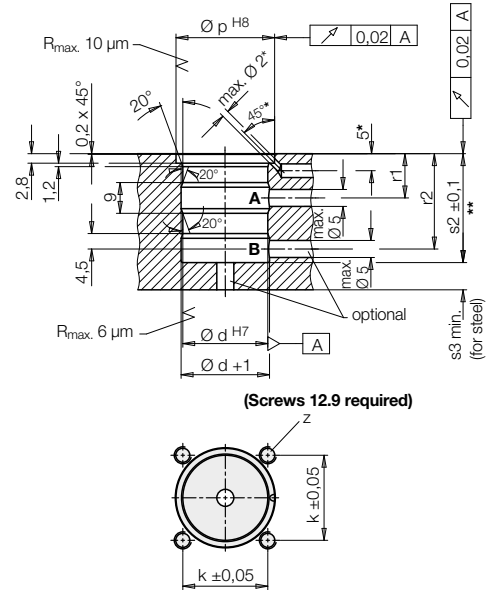

Effective clamping force and max. lever length e1 as a function of the operating pressure p

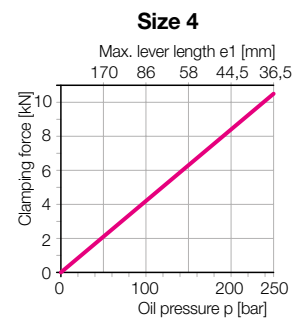
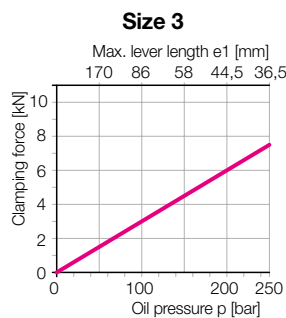
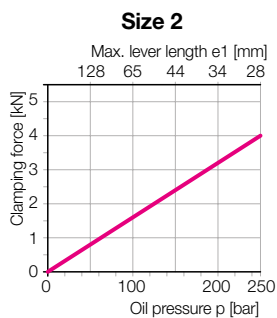
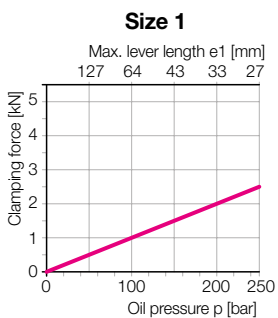

Technical data Dimensions

Size		1	2	3	4
Clamping force at 250 bar and Short clamping lever	[kN]	2.5	4.0	7.5	10.5
Max. stroke	[mm]	5	5	7	8.5
Clamping stroke, usable	[mm]	4.5	4.5	6.5	8
Piston Ø:	[mm]	18	22	28	33
Piston rod Ø	[mm]	11	14	17	19
Oil volume clamping	[cm ³]	2.3	3.2	6.4	10.5
Oil volume unclamping	[cm ³]	3.6	5.4	10.2	15.7
Max. flow rate	[cm ³ /s]	4	5.5	11	25
Min. operating pressure without clamping monitoring	[bar]	20	20	20	20
with clamping monitoring	[bar]	70	70	70	70
Min. air pressure	[bar]	3	3	3	3
α ±1	[°]	13.5	10.5	15	16
a1	[mm]	39.4	43	48.5	50.5
a2	[mm]	32	34	40.6	40.8
b	[mm]	6	7	10	10
c1	[mm]	5	5	7	8.5
c2	[mm]	14	12	7	8.5
Ød H7/f7	[mm]	25	32	40	45
e1	[mm]	27	28	36.5	36.5
e2	[mm]	59	60	67.5	67.5
f1	[mm]	25	26	32	35
f2	[mm]	32	31	32	35
g	[mm]	32.5	36.5	43	46
g1 max.*	[mm]	49.6	51	63.5	65.5
g2 min./max.*	[mm]	86/87.5	86/89.5	98.7/99.7	101/103
h1 max.	[mm]	20	20	22	23.5
h1 min.	[mm]	15.5	15.5	15.5	15.5
h2 max.	[mm]	3.5	2.5	5.5	7
h2 min.	[mm]	1	2	1	1
i	[mm]	43	46	44.5	47.5
k	[mm]	25	31	36.5	41
l	[mm]	34	42	48	55
m1	[mm]	5	6	8	8
m2	[mm]	19	24	32	35
n	[°]	47.2	55.8	56.1	62
Ø o	[mm]	5.2	6.2	6.2	8.2
Ø p H8	[mm]	29	36	44	49
r1	[mm]	13	13	14	14
r2	[mm]	28	28	31	31
s1 min.	[mm]	40	43.5	49	51
s2 ±0,1	[mm]	32.1	34.1	40.7	40.9
s3 min.	[mm]	6	7	9	10
z	[mm]	M5	M6	M6	M8

With pneumatic clamping monitoring

Version with cover

Part no. - short clamping lever	1801-110	1802-110	1803-110	1804-110
Weight, approx.	[kg] 0.3	0.53	0.92	1.17
Part no. - long clamping lever (blank)	1801-130	1802-130	1803-130	1804-130
Weight, approx.	[kg] 0.57	0.88	1.4	1.7

Version without cover**

Part no. - short clamping lever	1801-111	1802-111	1803-111***	1804-111
Weight, approx.	[kg] 0.27	0.46	0.82	1.03
Part no. - long clamping lever (blank)	1801-131	1802-131	1803-131***	1804-131
Weight, approx.	[kg] 0.54	0.82	1.3	1.56

With pneumatic unclamping monitoring

Part no. (version see above)	1801-1XXA	1802-1XXA	1803-1XXA	1804-1XXA
------------------------------	-----------	-----------	-----------	-----------

Without position monitoring

Part no. (version see above)	1801-1XXB	1802-1XXB	1803-1XXB	1804-1XXB
------------------------------	-----------	-----------	-----------	-----------

Accessories

Part no. - short clamping lever	3548-1121	3548-1122	3548-1123	3548-1124
Part no. - long clamping lever (blank)	3548-1071	3548-1072	3548-1073	3548-1074

* min. = height in unclamping position as presented. max. = max. height for swinging

** Use screw material 12.9; *** max. operating pressure 200 bar

Important notes!

The compact clamps are designed exclusively for clamping of workpieces in industrial applications. Hydraulic clamping elements can generate considerable forces. The workpiece, the fixture or the machine must be in the position to compensate these forces.

In the effective area of the piston rod and the clamping arm there is the danger of crushing. The manufacturer of the fixture or the machine

is obliged to provide effective protection devices. During loading and unloading of the fixture a collision with the clamping lever has to be avoided. Remedy: Mount position adaptor.

The height of the manifold surface of the compact clamp should be selected so that the clamping point is approximately in the centre of the usable clamping stroke.

The compact clamp has to be checked regularly

on contamination by swarf and has to be cleaned. For dry machining, minimum quantity lubrication and in case of accumulation of very small swarf or particles, regular disassembly, cleaning and lubrication of the lever mechanism as per operating manual is required.

Operating conditions, tolerances and other data see data sheet A 0.100 and A 0.130.

Accessories

Mounting body • Pneumatic position monitoring

Mounting body

for version with pipe thread and cover

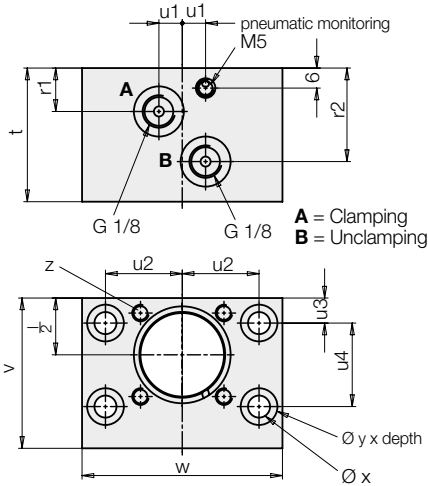

Size		1	2	3	4
l	[mm]	34	42	48	55
r1	[mm]	13	13	14	14
r2	[mm]	28	28	31	31
t	[mm]	40	44	50	52
u1	[mm]	7	7.5	10	10
u2	[mm]	23	26	31	34
u3	[mm]	7.5	7.5	8	8
u4	[mm]	25	28	34	38
v	[mm]	45	50	58	63
w	[mm]	60	65	78	85
Ø x	[mm]	6.6	6.6	8.5	8.5
Ø y x depth	[mm]	11 x 7	11 x 7	13.5 x 9	13.5 x 9
z	[mm]	M5	M6	M6	M8
Weight, approx.	[kg]	0.61	0.75	1.16	1.4
Part no.		3468-381	3468-382	3468-383	3468-384

Pneumatic position monitoring

1. Clamping monitoring

In the clamping area, the clamping lever slides downwards at two hardened surfaces of the body. In one of the surfaces there is the bore hole for the pneumatic clamping monitoring. The clamping lever overruns the bore hole, but does not completely close it. Only when the workpiece is really clamped, the clamping lever supports itself on the sliding surface and the bore hole will be firmly closed.

The clamping monitoring signals:

- The clamping lever is in the usable clamping range and
- a workpiece is clamped.

Important note

Required minimum pressures for clamping monitoring:

Hydraulics 70 bar
Pneumatics 3 bar

2. Unclamping monitoring

In the unclamping position the clamping lever closes a pneumatic bore hole.

Important note

The compact clamp is available with "clamping monitoring" or "unclamping monitoring". The control of both positions is not possible since the minimum dimensions of the housing allow only one pneumatic connection.

Monitoring by pneumatic pressure switch

For the evaluation of the pneumatic pressure increase, standard pneumatic pressure switches can be used.

With one pressure switch up to 8 compact clamps can be controlled.

Important note

Pneumatic position monitorings are only process-safe, when air pressure and air volume are precisely adjusted.

For measuring of the air volume, appropriate devices are available. Please contact us.

Clamping monitoring

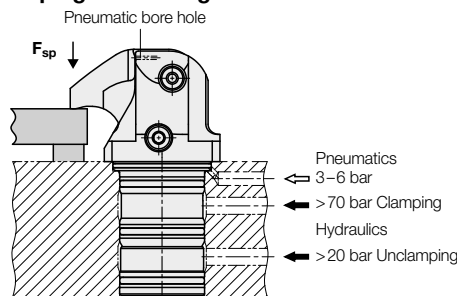

Example for clamping position

Required switching pressure 4.5 bar
Pressure drop, if 1 compact clamp is not clamped approx. 2 bar

As per diagram:

Required flow rate approx. 10-13 l/min
(depending on the number of connected compact clamps)

Unclamping monitoring

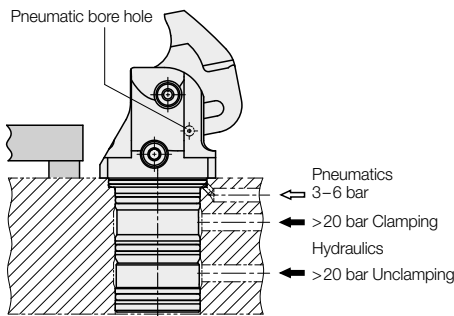

Example for unclamping position

Required switching pressure 4.5 bar
Pressure drop, if 1 compact clamp is not unclamped approx. 2 bar

As per diagram:

Required flow rate approx. 8.5-10 l/min
(depending on the number of connected compact clamps)

Function charts

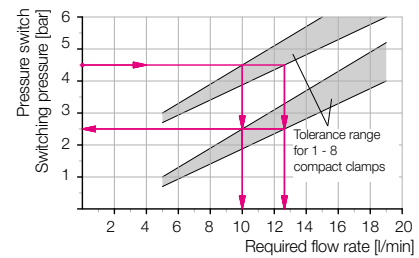
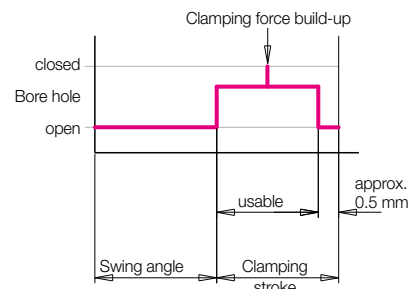

Required flow rate depending on the switching pressure of the pneumatic pressure switch for a pressure drop Δp 2 bar

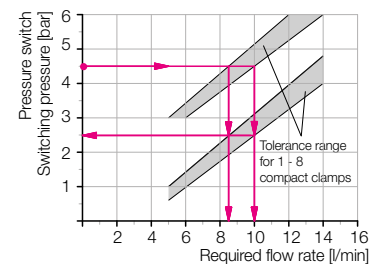
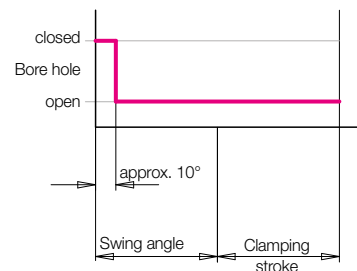

Required flow rate depending on the switching pressure of the pneumatic pressure switch for a pressure drop Δp 2 bar

